

# Service Parts & Dimensions – 1010-10.22

Effective: August, 2009 (replaces February, 1998)

## Model 7750 Tank Level Indicator

### Specifications – 7750 Pneumatic Column Display

#### ■ Operating Principle

Well-type manometer acts as a frictionless hydrostatic force-balance. A liquid fill is raised in direct proportion to the magnitude of pressure applied. (Varies based on type of indicating liquid employed.)

#### ■ Resolution

Infinite based on type of indicating liquid employed.

#### ■ Input Connection(s)

1/4" NPT tapped connection for typical tube fittings. Accepts pneumatic air/gas pressure input; high and low pressure inputs.

#### ■ Materials of Construction

Formed channel indicator housing; brushed Stainless Steel (type 304). Heavy plate glass window; acrylic plastic window available as special order.

#### ■ Wetted Parts

316 Stainless Steel liquid well and tubing.

#### ■ Indicating Tube

High strength, fully annealed glass (Pyrex®)

#### ■ KING-GAGE indicator

Single display tube. Available in wall mount housing only.

**Scale Ranges: 20", 35", 43", 51", 66", 81"**

### Dimensions by Indicator

Range (inches)

Range	Dim. "A"	Dim. "B"
20	26-1/4	25-3/8
35	42-1/4	41-3/8
43	50-1/4	49-3/8
51	58-1/4	57-3/8
66	74-1/4	73-3/8
81	90-1/4	89-3/8

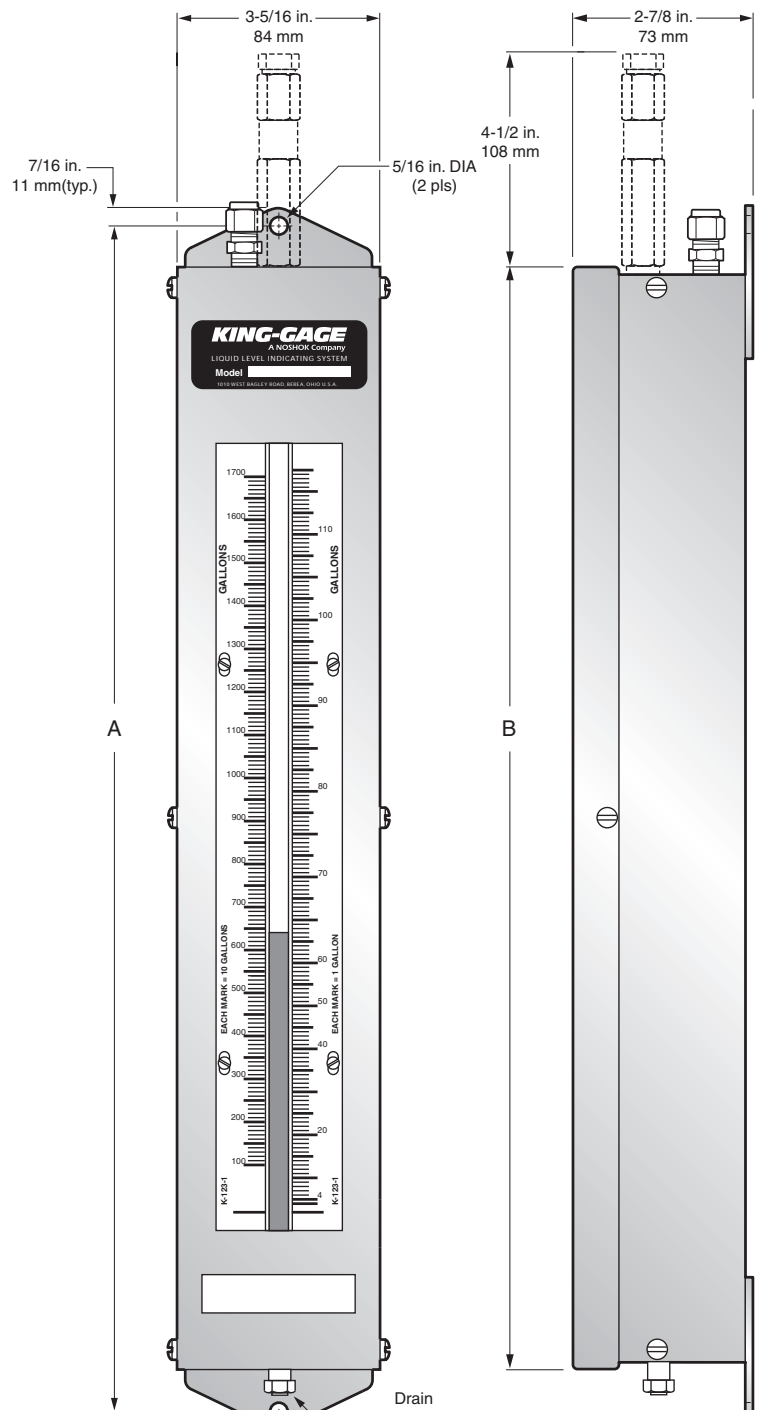

**Model 7750 Service Parts:**

Item	Description	Part No.	Qty.	Notes
1	Gage Repl. Well	7754-20, -35 7755-43, -51, -66	1 1	1 1 (includes: gage well fab., drain plug, nylon washer, pressure tube, & well conn. nut)
2	Drain Plug (included with item 1) Washer, Nylon (included with item 1)	7560 8806	1 1	
3	Glass Tube Repl. Kit (includes: glass tube, packing washers & o-rings)  Glass Tube Packing Seal Kit ... (includes: o-rings, packing washers & well conn. nut)	5159-x 5181-1	1 1	1 1
4	Gage Cover Assy. Stainless Steel w/ Glass	8815S-x	1	1,2
5	Glass & Molding Assy. (included with item 4)	8866-x	1	
6	Top Plate	5143S-1	1	2
7	Bottom Plate	5142S-1	1	2
8	Check Valve	8838	1	
9	Vent Plug	6560	1	
10	Replacement Scales 1-Unit Scales 2-Unit Scales	7083-x 7084-x	1 1	1,5 1,5
11	Replacement Liquid Red, No. 294 Purple, No. 175 Mercury	2992-x 9175-x 2604-3-1	1 1 1	3 3 4
12	Reflector	7761-x	1	1
13	Tube Fitting (Swagelok)	84378-2B	1	

**Notes:**

1. Dash number indicates range.
2. (S) indicates stainless steel.
3. Dash number indicates bottle size (8 or 16 oz. bottles only).
4. Sold by weight (1 lb. bottles only).
5. When ordering a replacement scale, the following information must be supplied:
  - Tank Designation
  - Unit(s) of measurement
  - Scale serial number
  - Specific gravity, product density, etc.

