

Service Parts & Dimensions 1060-27.00

Effective: October 2014

KING-GAGE AcraSensor Diaphragm Units Model Numbers 8999-1-5, 8999-2-5, 8999-3-5

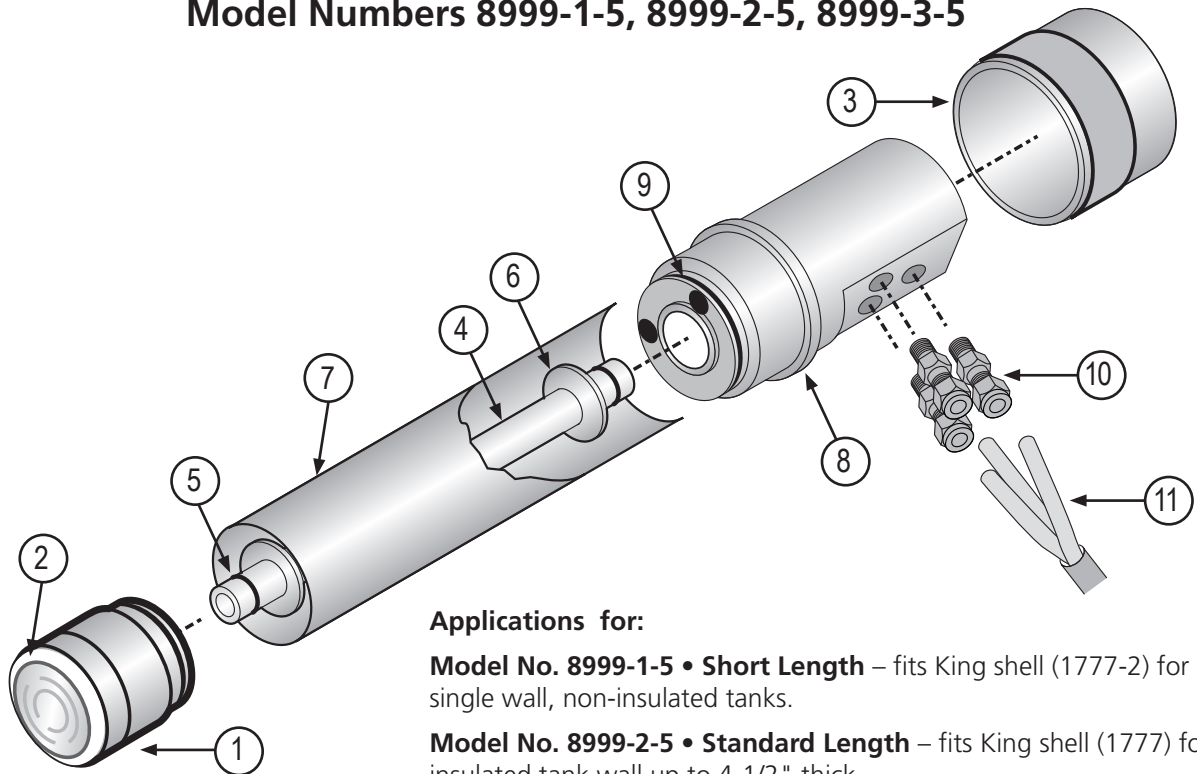

Applications for:

Model No. 8999-1-5 • Short Length – fits King shell (1777-2) for single wall, non-insulated tanks.

Model No. 8999-2-5 • Standard Length – fits King shell (1777) for insulated tank wall up to 4-1/2" thick.

Model No. 8999-3-5 • Long length – fits King shell (1777-3) for insulated tank wall up to 6-3/4" thick.

Item	Description	Model No. 8999-1-5	Model No. 8999-2-5	Model No. 8999-3-5
1	Titanium sensing diaphragm (includes item 2)	S-1618-3	S-1618-3	S-1618-3
2	Replacement Teflon O-ring	1786-40	1786-40	1786-40
3	AcraSensor nut	KE1751	KE1751	KE1751
4	Post assembly (includes items 5 & 6)	7859-1	7859-2	7859-3
5	O-ring (2 required)	6554-7	6554-7	6554-7
6	Spring washers (2 required)	3038	3038	3038
7	Housing	5611-21	5611-22	5611-23
8	Replacement connector kit (includes items 9 & 10)	1752-30-3	1752-30-3	1752-30-3
9	O-ring	6495-222	6495-222	6495-222
10	1/8 NPT x 1/4 tube fitting, stainless steel (3 required)	8437S-22	8437S-22	8437S-22
11	3-tube cable (15 ft. length)	1766-15	1766-15	1766-15
	3-tube Cable (per foot)	8014-xx	8014-xx	8014-xx

3-tube cable (item 11) is available in standard 15 ft. length (p/n 1766-15). For lengths over 15 ft., order p/n 8014-x and specify total length (in feet) required (-xx represents number of feet specified).

Dimensional Data:**Short (8999-1-5)**

- Overall length 4 inches

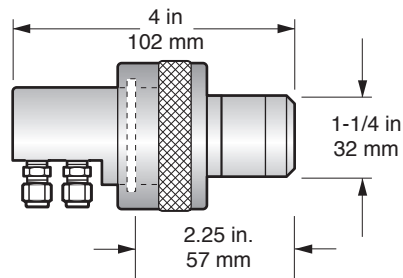
**Standard (8999-2-5)**

- Overall length 8-3/8 inches

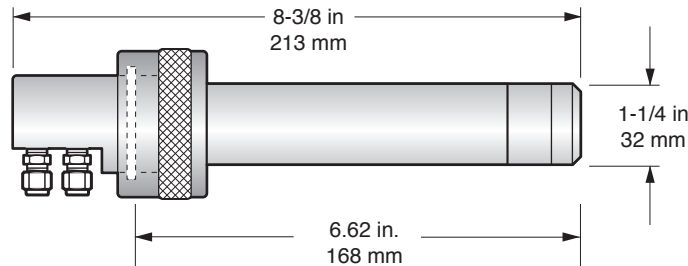
**Long (8999-3-5)**

- Overall length 10-5/8 inches

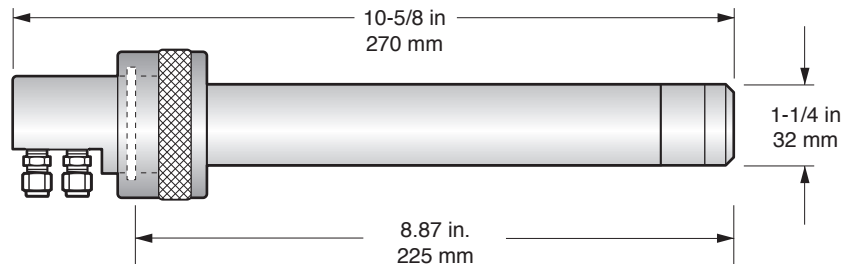
**CLEANING PROCEDURE (Seal Failure)**

In the event of leakage past the O-ring sealing the unit within the tank penetration, perform the following steps and replace the O-ring:

- Remove the AcraSensor unit fully from the tank mounting shell.
- Disassemble the sensing diaphragm from the post and housing (see exploded diagram).
- Clean all EXTERNAL surfaces thoroughly using approved sanitizing solution. DO NOT IMMERSE sensing diaphragm!
- Replace O-ring seal (1786-40). Reassemble cleaned parts and reinstall into tank shell.