

# Air-Guard Dual Stage Filter 80 SCFM

## 2479 SERIES



- Large capacity filter designed to remove particulate dust, water/oil aerosols, and condensation often present in main compressed air supply lines
- Supplied with KING Type 750/800 element set that includes coalescing scrubber and adsorptive polisher cartridges, Type 300/300 element set is optional

### SPECIFICATIONS

Maximum pressure	150 psi
Rated flow	80 scfm @ 100 psig; 2265 l/min @ 7 Kg/cm2; 136 m3/hr @ 7 bar
Connections	1" NPT
Filter type	Dual cartridge coalescing elements
Housing	Aluminum
Sump	Aluminum
Efficiency	99.98% @ 0.1 micron
Weight	15.0 lb/7 kg

### APPLICATIONS

- Provides clean air to meet individual process requirements



ORDERING INFORMATION		
SERIES	2479 Air-Guard Dual Stage Filter 80 SCFM	
DRAIN TYPES	1 With manual drain	1T With auto drain
EFFICIENCY	6-5 99.998% @ 0.1 micron	1-1 98% @ 2.0 micron

**EXAMPLE**

Series .....2479 Series  
 Drain type..... With auto drain  
 Efficiency ..... 98% @ 2.0 micron

**2479 - 1T - 1-1**

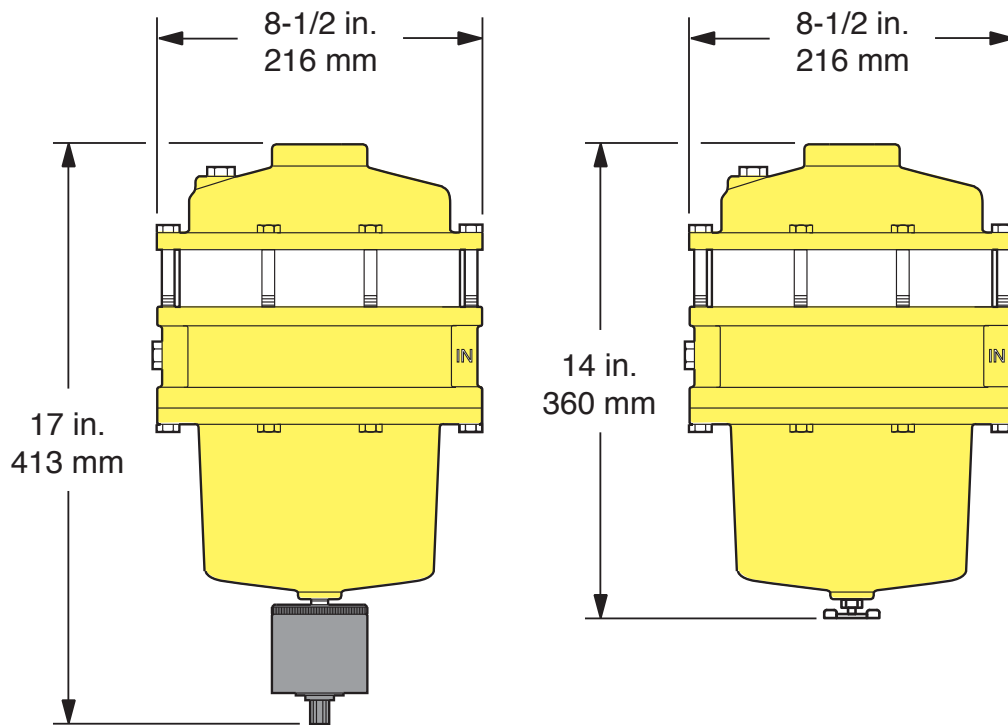

Replacement Cartridge Sets
22-41-6-5 - Type 750/800 (0.1 micron)
22-41-1-1 - Type 300/300 (2.0 micron)