

Signal Loop and Pressure Input Connections

Pressure (Pneumatic) Input

The D/P Transmitter is designed to generate a 4-20 milliamp electrical signal in direct proportion to pressure inputs. It is intended for clean, dry air or gas pressure media. Tube fittings, if supplied, are for 1/4 inch (O.D.) tubing.

"S" - High pressure input

"E" - Low pressure input

(Vents to atmosphere if no external connection is required - use supplied vent plug.)

Signal Connections (4-20 mA Current Loop)

Screw clamp terminals are provided for positive (+) and negative or common (-) sides of the signal loop.

As is typical of two-wire transmitters, all electrical power is supplied through the signal loop wiring. Refer to the following diagram for proper wiring of the 4-20 mA loop circuit:

Power Requirement

The D/P Transmitter requires a source of DC power for operation. Minimum excitation voltage must be no less than 10 Vdc. Any receiver installed on the signal loop (meters, data loggers, controllers, etc.) must be taken into account when determining the required power supply voltage to be used. The internal resistance of each device added together represents the total "load" residing on the signal loop circuit.

$$\text{Load Capacity} = \frac{(\text{Supply Voltage} - 12 \text{ Volts})}{(\text{ohms}) \quad .02}$$

Load Capacity at Supplied Voltage

20 Vdc	24 Vdc	28 Vdc	32 Vdc	36 Vdc	40 Vdc
400 ohms	600 ohms	800 ohms	1000 ohms	1200 ohms	1400 ohms

KING-GAGE LP2 tank processors and LevelBAR indicators provide 24 Vdc excitation to power the signal loop circuit. (If the application requirement exceeds 600 ohms, an external power supply of appropriate voltage will be required.)

Signal Cabling

The 4-20 mA signal loop needs to be run using twisted pair (two conductor) cable. "Noise" or EMI (electromagnetic interference) does not generally create a problem since it is common to both wires in the pair and essentially cancels itself out. In most applications, non-shielded twisted pair instrumentation cable (20-22 AWG) will be suitable for the signal loop between the D/P Transmitter and receiver.

KING-GAGE
A NOSHOK Company
D/P Transmitter
Range: 0-10 psid Output: 4-20 mA
Model 5600-3-1 Serial No. K3158

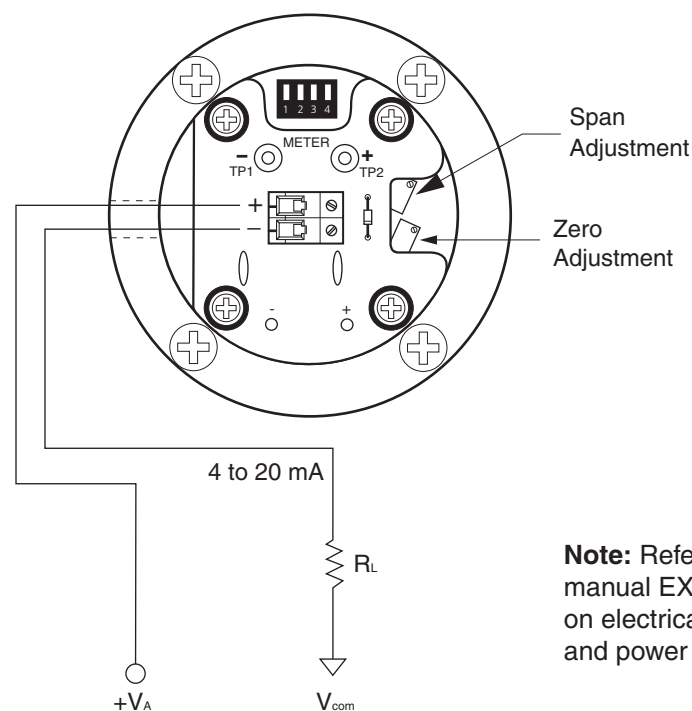
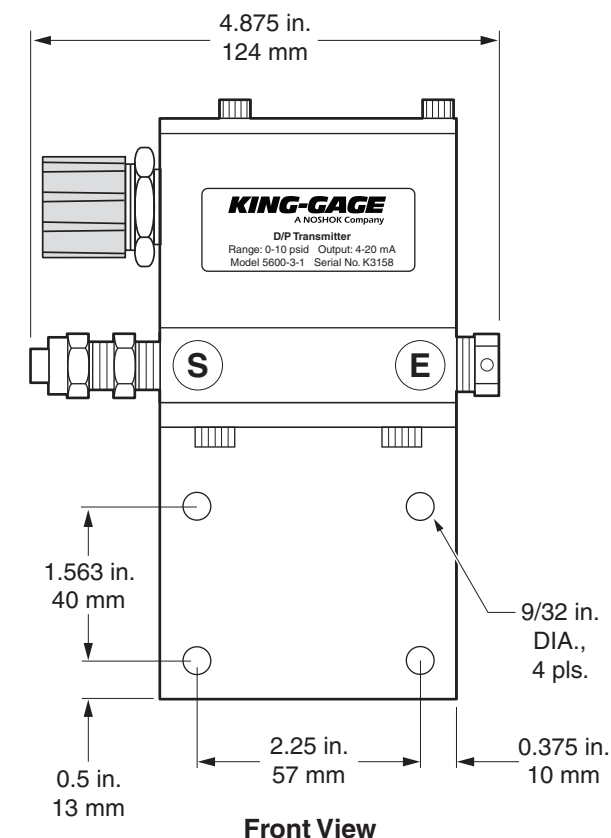
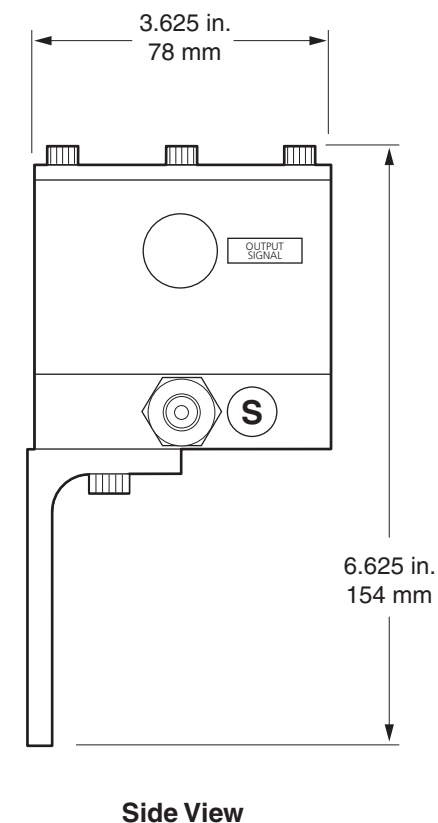
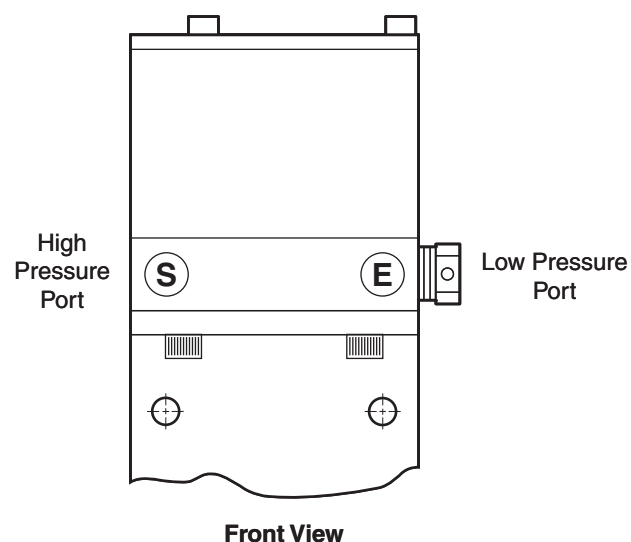

Note: Refer to instruction manual EX-1673-2 for details on electrical signal connections and power requirements.

Transmitter Installation

Many applications require the D/P Transmitter to be situated in harsh environments. Any proposed location should afford some protection against shock and vibration. If possible, locate the unit to minimize exposure to wide temperature extremes.

The 5600 D/P Transmitter is designed to use in conjunction with a KING-GAGE pneumatic tank sensor. It converts the 1:1 pressure output of the sensor to a proportional electronic signal. **IMPORTANT!** – The transmitter is designed for clean, dry and oil-free air or gas pressure input only. Moisture and/or other contaminants may lead to rapid deterioration of the internal electronics.

Select a suitable mounting location (see above) as close as practical to the tank. If the transmitter will be "teed" into an existing pneumatic signal line, the location should be selected to minimize the length of tubing runs.

INSTALLATION INSTRUCTIONS

Differential Pressure Transmitter Model 5600

D	9/10	Revised Load Capacity	DATE	09/22/10
C	6/08	Strain Relief Connector		
B	5/03	Revised w/ new format	DRAWN BY	H. Emrick
A	2/87	Released	APPROVED	

KING-GAGE
A NOSHOK Company

1010 West Bagley Rd., Berea, Ohio 44017
Ph 855.367.2494 www.king-gage.com

DWG. NO. **K-1090-1-5600**

SHEET 1 OF 1

REV. **D**