

ES3 Sanitary



58 SERIES

- Standard flush mount
- 4:1 turn down
- Multiple process connections
- Electronic (4 mA to 20 mA) output
- Consistent output during CIP cycles
- HART® protocol output available
- All transmitters are fully temperature compensated

APPLICATIONS

- Food & beverage
- Chemical processing
- Power generation
- Pharmaceutical
- Water & wastewater
- Pulp & paper
- Marine

SPECIFICATIONS

Span adjustment range*	Transmitter turndown ratio is 4:1 for all ranges.		
	Nominal	Minimum	Range of Adjustment
	0–5.8 psig	0–1.45 psig	0–40 inH ₂ O through 0–160 inH ₂ O 0–1 m through 0–4 m water
	0–23 psig	5.8 psig	0–160 inH ₂ O through 0–630 inH ₂ O 0–4 m through 0–16 m water
	0–58 psig	0–14.5 psig	0–394 inH ₂ O through 0–1575 inH ₂ O/ 0–10 m through 0–40 m water
	0–145 psig	0–29 psig	
	0–350 psig	0–87 psig	
Operating limit (maximum pressure)	Pressure above 300% nominal range (over-range) will result in damage to the transmitter (200% may cause a shift in calibration).		
Accuracy	Less than ±0.20% Adjusted Span Includes linearity, hysteresis, non-repeatability errors.		
Pressure media	Gas or liquids compatible with Hastelloy (diaphragm); Silicone rubber (o-ring). All other wetted parts 316L.		
Electrical	Input (excitation): 14 Vdc to 36 Vdc Output (mA): 4 mA to 20 mA HART® protocol (optional)		
Linearity (worst case)	Less than ±0.13% full scale Hysteresis (worst case) Less than 0.05% full scale		
Non-repeatability (worst case)	Less than 0.02% full scale		
Operating temperature range	-4 °F to 212 °F / -20 °C to 100 °C		

* IMPORTANT! Accuracy, linearity, and non-repeatability values are based on adjusted span range.



ORDERING INFORMATION			
SERIES	58		
PROCESS CONNECTIONS	01 KING Short	02 KING Standard	03 KING Long
OPTIONS	01 Standard options	04 Hart® protocol	
	02 Transparent cover	06 Transparent cover + Hart®	
SPAN RANGES	01 1.5 psi to 5.8 psi	03 14.5 psi to 58 psi	05 87 psi to 350 psi
	02 5.8 psi to 23.2 psi	04 29 psi to 145 psi	

EXAMPLE

Series 58 Series 58 01 - 02 - 04
 Process connection KING short
 Option Transparent cover
 Span range 29 psi to 145 psi

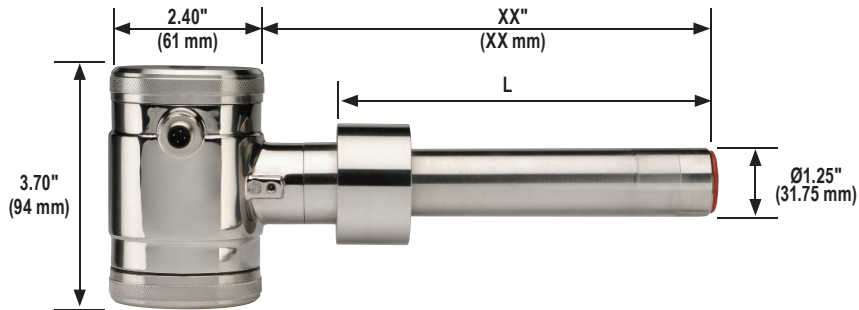

L	
Short	2.19" (55.63 mm)
Standard	6.62" (168.15 mm)
Long	8.81" (223.77 mm)



M12 Connector

CONNECTION 2-WIRE - 4 mA to 20 mA

- 1 - Brown Positive (+)
- 2 - White Negative (-)
- 3 - Blue Not Used
- 4 - Black Not Used