

## Model 5880-1

Effective: January, 2012

DATA SHEET 1400-10

# Multi-Point Process Switch

- **4 Adjustable Set Points**
- **Controls Simple Process Functions**
- **Independent SPDT (Form C) Relays**
- **For Process Transmitters with 4-20 mA Output**

Multi-Point Process Switch is a single channel analog set-point control. It provides continuous monitoring of a typical process loop with four (4) independent set-points that are user adjustable over the full range. The process Switch may be used in conjunction with any process transmitter (i.e., pressure, level, temperature) that incorporates a two-wire, 4-20 mA output.

### SPDT Relay Output

Control output relays are included for each set-point. During operation, the relay is energized once the milliamp value is exceeded. Both normally-open (N.O.) and normally-closed (N.C.) contacts are provided with the Form-C type relays. These SPDT relays are rated 3.0 Amps @ 115 Vac.

### Adjustable Deadband Range

An integral deadband is selectable for the set-point values offering up to 12.5 % F.S. adjustability. This deadband is adjustable for the set-points as a group (i.e., not independently adjustable for each set-point). The Multi-Point Process Switch is factory preset with a nominal 1% F.S. deadband.

### Automatic Overload Reset

This unit features protection against input circuit overloads and automatically resets when current level drops. Using advanced PTC resistor technology, the protection circuit trips whenever the signal input current exceeds 70 mAdc.



**Model 5880-1  
Process Switch**

## Process Applications

The Process Switch can be used to control continuous process operations, provide fail-safe limiting or alarm functions. In a level application, the switch can be used to actuate pumps, outlet valves or even to initiate CIP cycles. The Multi-Point Process Switch can monitor process variables within any industrial control environment.

MULTI-POINT Process Switch offers greater accuracy than conventional alarm trips. Monitors and triggers simple process functions more easily as compared to PID controllers, PLCs or other logic devices.

## Input Current Limiting

A positive temperature coefficient (PTC) resistor circuit is incorporated into the Process Switch for protection against overcurrent situations. This thermal resistor undergoes increased orders of magnitude in resistance when an input current  $\geq 70.0$  mA<sub>dc</sub> heats it above a certain point. In the switched state, a latched high-resistance limits current to no more than a few milliamps.

The resistor circuit resets automatically, permitting normal current flow once the input drops below 70 mA<sub>dc</sub>. (NOTE - Protective resistor circuit is rated for 30 trip/cycles max.)

### Diagram of Typical Process Loop

Voltage supply (  $+V_A$  ) provides power to process transmitter which outputs 4-20 mA signal through the loop.

**Process Switch** is wired into loop to receive signal. Internal PTC resistor provides overcurrent protection by limiting input through high-resistance.

(See "Input Current Limiting")

## 4-20 mA Input Signal

The Multi-Point Process Switch is a single channel analog set-point control. It provides continuous monitoring of a typical process loop with four (4) independent set-points that are user adjustable over the full input range. The Process Switch accepts any proportional, externally-powered two-wire 4-20 mA<sub>dc</sub> current loop from any typical process transmitter (level, pressure or temperature).

Unit must be wired in series with transmitter to maintain proper polarity at the + and - terminals. See Diagram.

Internal input resistance of the Process Switch is 132 ohms (nominal) during normal operation.

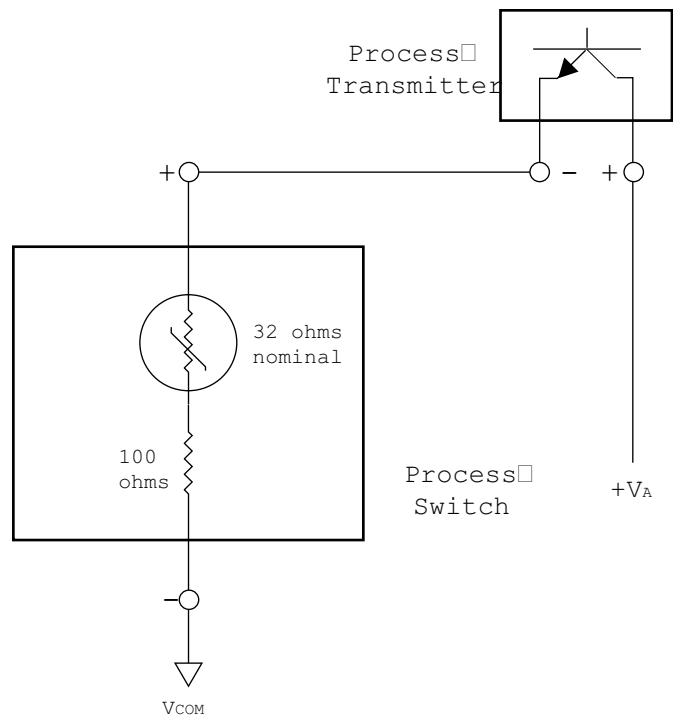

**Dimensions**

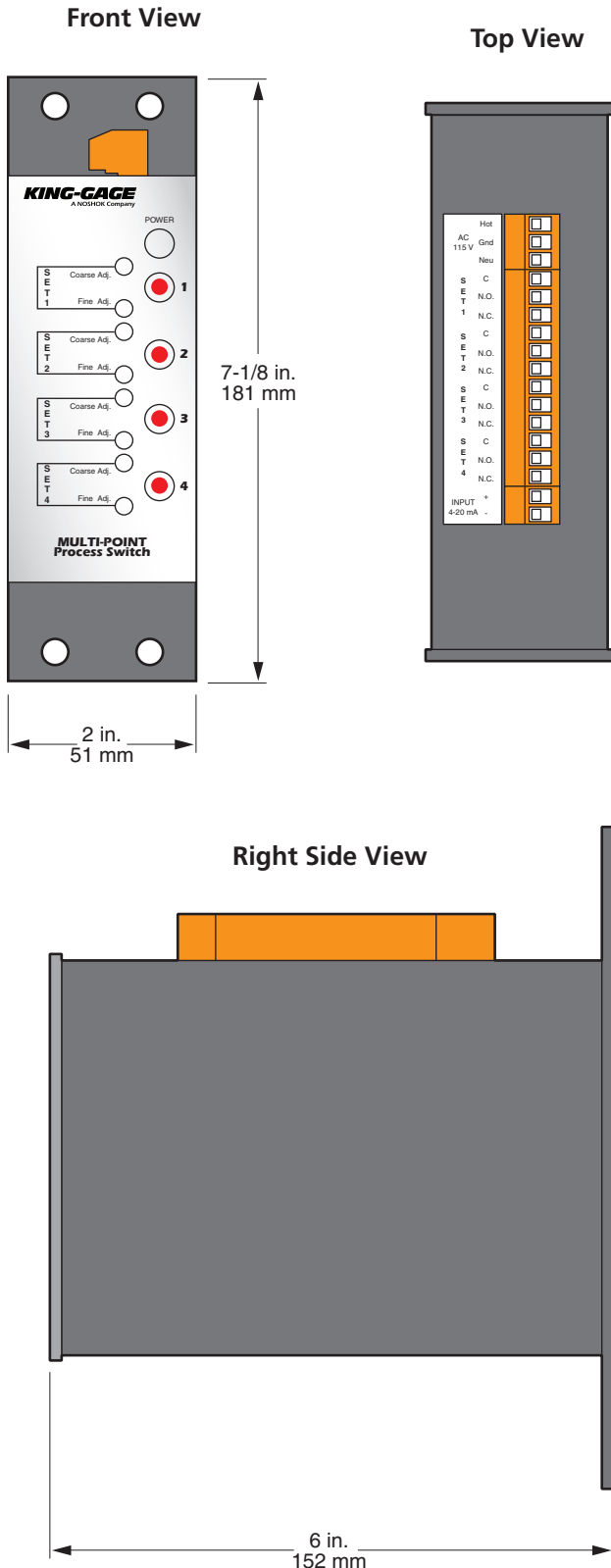

**Specifications**

**Power Requirements**

Nominal 115 Vac./60 Hz. (unregulated)  
3.45 Watt/0.03 Amp – fused @ 0.1 Amp

**Temperature Range (Environmental)**

32° F to 158° F/0° C to 70° C – operating  
(-40° F to 158° F/-40° C to 70° C – storage)

**Input**

dc current: 4-20 mA

**Current Limiting (Overload)**

70 mAdc maximum; automatic trip/reset using PTC resistor (positive temperature coefficient) circuit

**Input Impedance**

132 Ohm resistance (3 Vdc drop @ 20 mAdc)

**Set-Points**

(4) four independent user set-points; continuously adjustable over full input range. Front panel LED status indicator gives visual confirmation when set-point value has been exceeded.

**Sensitivity (Adjustment)**

Set-points can be adjusted to better than 0.05% FS/0.008 mAdc

**Repeatability**

Set-point settings are repeatable to better than 0.05% (long-term repeatability: better than 0.1% FS)

**Deadband**

Single deadband potentiometer controls all four set-point settings. Deadband adjustable from 1.0%-12.5% FS. (Factory preset to 1% FS.)

**Output**

(4) independent SPDT (form-C) relays; maximum 3.0 Amp @ 115 Vac. or 24 Vdc (resistive). Rated for 100,000 cycles/life at rated load.

**Size/Weight**

7-1/8" (H) x 2" (W) x 6" (D)  
22 oz./624 g.

# Multi-Point™

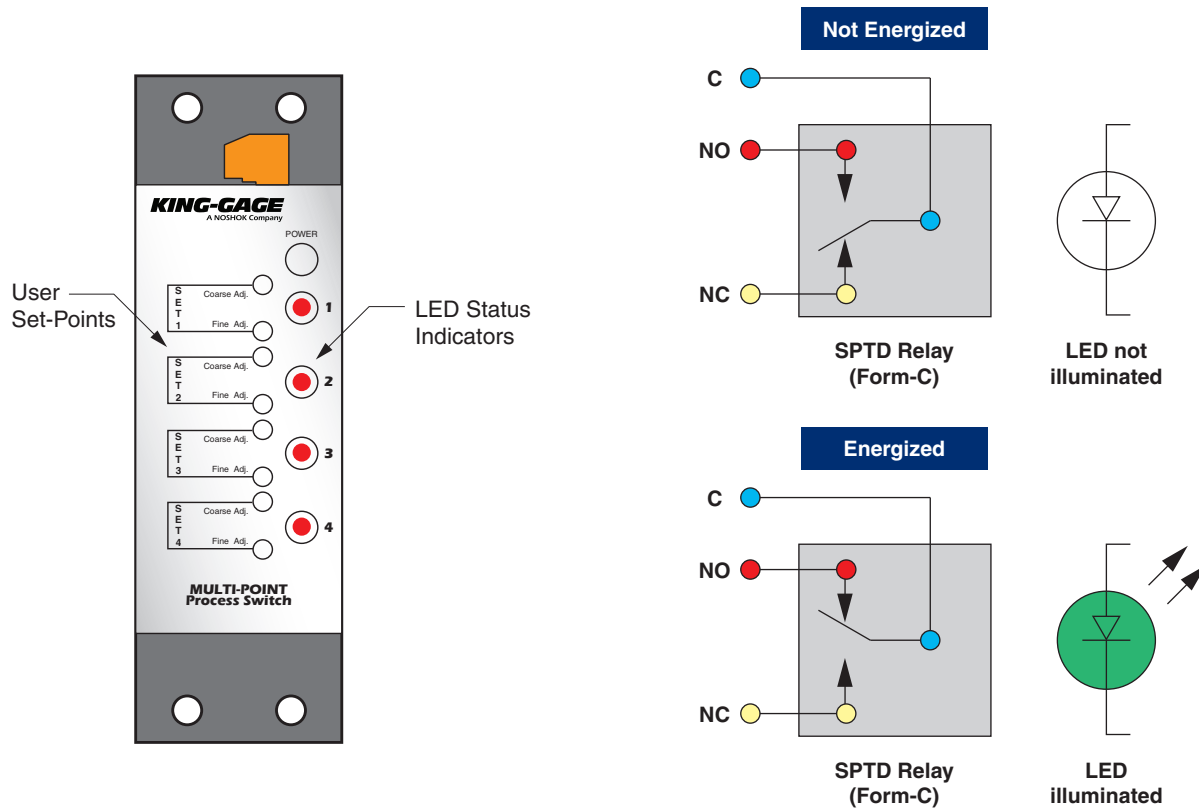

## Adjustable Set-Points

The Process Switch has four (4) user set-points that can be adjusted to control continuous process operations, provide fail-safe limiting or alarm functions.

**Front Panel** - LED Status Indicators are located on the front panel of the Process Switch. Each of the four (4) LEDs correspond to "SET1, SET2, SET3, SET4" adjustments and output relays. When illuminated, the LED indicates that the set-point has been reached and corresponding relay energized.

## SPDT (Form-C) Output Relays

Four (4) independent SPDT (single-pole/double-throw) relays are provided on the Process Switch. Form-C configuration includes normally-open (N.O.), normally-closed (N.C.) and common (C) relay contacts. Rated for 3.0 Amps maximum @ nominal 115 Vac.

Relay is energized when corresponding set-point milliamp value is exceeded.