

## Models 738, 788, 860, 868, 5600

Effective: January 2012

DATA SHEET 1100-40

# D/P Sensor Control

- Piezoresistive element for less frequent recalibration
- 4 mA to 20 mA two wire output for monitoring or control
- Better than  $\pm 0.02\%$  span repeatability

Liquid level gauging demands a high degree of accuracy and repeatability. This is especially true for quality control in batch processing operations. That is why KING-GAGE® D/P Transmitters are specifically designed to provide optimal performance in tank gauging applications. They utilize a precision piezoresistive sensor element that provides longer term stability. Guaranteed accuracy is within  $\pm 0.2\%$  F.S. and repeatable to within  $\pm 0.02\%$  of calibrated span.

### Pressure to mA Conversion

KING-GAGE D/P Transmitters accept either gage or differential pressure pneumatic inputs that are converted to a proportional 4–20 mA output signal. This two wire signal loop is compatible with typical process components that accept analog input including PLCs. Designed to operate over a broad voltage range, these transmitters work with power sources ranging from 14–40 Vdc (based on load requirements).

Output current limiting and continuous no-load operation ensures reliability in even the most demanding situations. Isolated test meter terminals permit in-process monitoring for troubleshooting. This allows the user to easily check the transmitter output without having to remove it from the process loop circuit.

**D/P Sensor Control provides 4 mA to 20 mA output for pneumatic sensor**

### Pressure Ranges are Span Adjustable

Transmitter span accommodates a 3:1 turndown ratio\* to match the application pressure range (i.e., tank depth). This permits ranging of the device to provide full scale output for maximum resolution in process control operations. Individual transmitter ranges of 0–5 through 0–50 psid are offered. These yield far greater stability than comparable single range units requiring high turndown ratios to fit the application.



\*3:1 turndown ratio is applicable to 0–10 and 0–30 nominal range, refer to specifications for detailed span adjustment available on specific range models.

**D/P Pneumatic Sensor Controls**

The KING-GAGE D/P Transmitter is also offered in a hybrid version combined with an air flow control for pneumatic sensors or downpipe (bubbler) systems. These combination units allow for direct 4–20 mA signal from the tank using the integrated differential pressure transmitter.

**D/P Sensor Controls** are designed for use with KING-GAGE pneumatic diaphragm sensors. The air control portion of these units creates a 1:1 pneumatic pressure directly proportional to liquid depth in the tank. Acting as a force balance, the pneumatic pressure offsets the hydrostatic pressure exerted against a diaphragm at the tank. The electronic transmitter then converts this pressure into a 4–20 mA output signal.

**D/P LiquiSeal Controls** and **D/P Purge Controls** are used in conjunction with a downpipe (or bubble tube) extending down through the liquid contents of the tank. This type of sensor also acts as a force balance. A continuous purge of compressed air into the pipe displaces the liquid and creates a pneumatic pressure equivalent to hydrostatic head pressure. The transmitter converts this pressure into a 4–20 mA output signal.

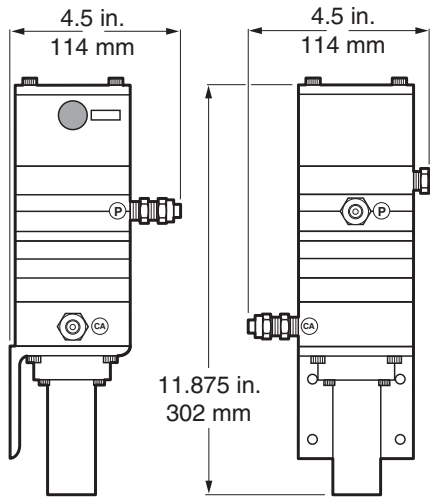

**738 D/P LiquiSeal™ Purge Control**

D/P transmitter combined with downpipe purge control. 1/4" NPT pressure connection(s) and 1/2" NPSF (Dryseal) conduit connection.

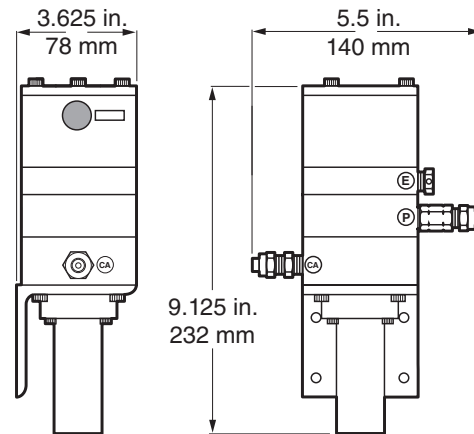

**788 D/P Purge Control**

D/P transmitter integrated with downpipe purge control. 1/4" NPT pressure connection(s) and 1/2" NPSF (Dryseal) conduit connection.

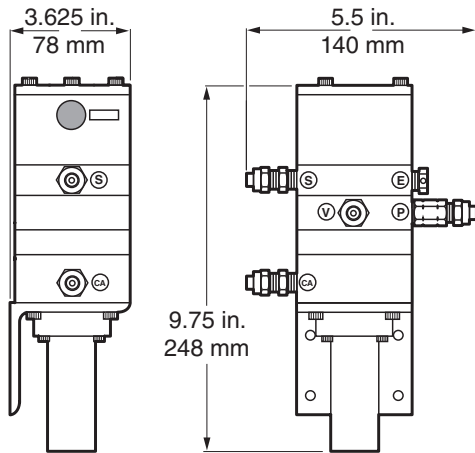

**868 D/P Sensor Control**

D/P transmitter integrated with pneumatic sensor control. 1/4" NPT pressure connection(s) and 1/2" NPSF (Dryseal) conduit connection.

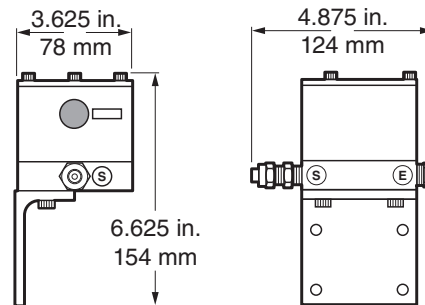

**5600 D/P Transmitter**

D/P transmitter for independent mounting or system retrofit. 1/4" NPT pressure connection(s) and 1/2" NPSF (Dryseal) conduit connection.

### Span Adjustments

Transmitter turndown ratio is 3:1 for the 0–15, 0–30, 0–50 psid nominal ranges.

**Nominal Minimum Range of Adjustment**

0–5 psid	0–3 psid	0–83 in. thru 0–138 in. water/0–2.1 m thru 0–3.5 m water
0–10 psid	0–3 psid	0–83 in. thru 0–277 in. water/0–2.1 m thru 0–7.0 m water
0–15 psid	0–3 psid	0–83 in. thru 0–415 in. water/0–2.1 m thru 0–10.5 m water
0–30 psid	0–10 psid	0–277 in. thru 0–830 in. water/0–7.0 m thru 0–21.0 m water
0–50 psid	0–15 psid	0–415 in. thru 0–1384 in. water/0–10.5 m thru 0–35.1 m water

IMPORTANT! Accuracy, linearity, and non-repeatability values are based on nominal range.

### Operating Limit (Maximum Pressure)

Pressure above 300% nominal range (overrange) will result in damage to the transmitter (200% may cause a shift in calibration). Burst pressure is 200 psi and will cause catastrophic and physical failure of the pressure element.

### Voltage/Load Capacity Ratings

The KING-GAGE D/P Transmitter requires a source of DC power for operation. The minimum excitation voltage necessary for the transmitter is 10 Vdc. Any receiving components (meters, data recorders, programmable controllers, etc.) installed in the process loop circuit must be taken into account when determining the required power supply voltage. The internal resistance of each device added together represents the total “load” residing on the circuit loop.

The following equation and chart represent the relationship between power supply voltage and load capacity (expressed in ohms) of the output signal from the D/P Module:

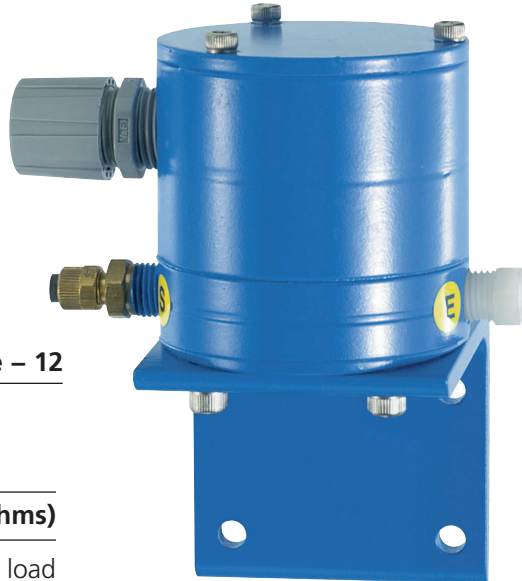

$$\text{Max. Load Capacity} = \frac{\text{Voltage} - 12}{(\text{Ohms}) \quad .02}$$

Voltage	Capacity (Ohms)
14 Vdc.....	100 Ω load
16 Vdc.....	200 Ω load
24 Vdc.....	600 Ω load
28 Vdc.....	1000 Ω load
40 Vdc (max.) .....	1400 Ω load

### D/P Transmitter Specifications

**Output Signal**  
4–20 milliamperes (mA<sub>dc</sub>)

**Accuracy**  
±0.2% F.S. (±0.10% F.S., typical)  
includes non-linearity, hysteresis and non-repeatability

**Repeatability**  
±0.02% of calibrated span

**Temperature Range**  
0° to 180°F / -18° to 82°C  
(operating range)

**Compensated Temperature Range**  
32° to 120°F / 0° to 54°C

**Thermal Effects** (over compensated temperature range)  
less than .007% °F (.011% °C) span shift—sensitivity  
less than .007% °F (.011% °C) span shift—zero

**Power Supply Voltage**  
14–40 Vdc (unregulated)

**Power Supply Stability**  
(effect on FSO)  
Less than .005% of span change in output per volt change at input terminals

**Burst Pressure**  
200 psi

### D/P Sensor Control or D/P Purge Controls

**Combined Accuracy\***  
0–5 psid trans./control .....±0.34% FS  
0–10 psid trans./control ...±0.27% FS  
0–15 psid trans./control ...±0.24% FS  
0–30 psid trans./control ...±0.22% FS  
0–50 psid trans./control ...±0.21% FS

**Compressed Air Requirement**  
35–150 psig supply pressure at control inlet

**Maximum Depth Measurement**  
1,937 in. water (49.0 m water)

\*Combined accuracy refers to the primary accuracy of the pneumatic sensor in combination with the secondary accuracy of the D/P transmitter.

### Tank Gauging Applications

Acting on the force balance principle, a pneumatic sensor generates air pressure equivalent to the hydrostatic force created by liquid depth. This pneumatic pressure is directed into the D/P transmitter. Pressure is converted to an electronic 4–20 mA dc output proportional to liquid depth. Twisted pair cabling is used to form the signal loop through which the remote indicator receives the transmitter output.

The KING-GAGE® indicators shown in these system views correlate the transmitter output to total volume or weight of tank contents. This is determined by using a pressure versus capacity listing corresponding to the actual tank dimensions.

### Transmitter Signal Loop

As is typical of two wire transmitters, electrical power to the signal loop is supplied through twisted pair cable. Excitation voltage (+V) is provided by the receiving device or from a separate Vdc power supply installed in the loop. The actual voltage necessary for operation of the system will depend upon the overall load resistance of the loop.

In most applications, the KING-GAGE Digital Indicator or LevelBAR indicator provides 24 Vdc excitation to power the transmitter signal loop.

