

## 92 SERIES



- External mounting at tank
- Pneumatic output, or electronic (4 mA to 20 mA) output when paired with KING-GAGE 860 Series Sensor Control or 868 Series D/P Purge Control
- Unaffected by foam or vapor
- Safe for hazardous environments
- Virtually free from long term drift, hysteresis and temperature sensitivity unlike strain measurements (including load cells) since mechanical deflection of the diaphragm is not directly measured
- The compensating pneumatic balance pressure which effectively isolates the sensor is converted to a proportional 4 mAdc to 20 mAdc signal or can be directly output to a suitable gauge

### APPLICATIONS

- Chemical processing
- Power generation
- Pharmaceutical
- Water & wastewater
- Pulp & paper
- Marine

### SPECIFICATIONS

<b>Sensitivity</b>	Better than .001 psi ( $\pm .02$ inH <sub>2</sub> O/.508 mm water)
<b>Repeatability</b>	Better than $\pm .002$ psi ( $\pm .05$ inH <sub>2</sub> O/1.27 mm water)
<b>Primary accuracy</b>	$\pm .007$ psi ( $\pm 0.2$ inH <sub>2</sub> O/.508 mm water)
<b>Temperature range</b>	30 °F to 300 °F (0 °C to 149 °C)
<b>Pressure range</b>	Sensor is a 1:1 pneumatic force balance diaphragm capable of repeating hydrostatic pressure as an equivalent pneumatic output. Functional pressure limit is 130 psi (or 3598 inches @ 1.00 specific gravity) determined by supply pressure (35–150 psi) less 20 psi.
<b>Maximum depth measurement</b>	1937 inH <sub>2</sub> O (49.0 m water)
<b>Wetted materials</b>	FKM O-ring, Titanium diaphragm, commercially pure. Optional diaphragm materials: Silicone rubber Mounting flange options: 316L Stainless, PVC, brewery special flange
<b>Air Consumption</b>	Total air consumption of sensor package (including sensor control) is less than 10 CFH or 0.16 scfm
<b>Compressed air supply requirements</b>	35 psig to 150 psig (2.4–10.3 bar); clean, dry air (or inert gas)



ORDERING INFORMATION			
SERIES	92		
FLANGE SIZES*	2 2" Flange	3 3" Flange	4 4" Flange
FLANGE MATERIALS	71 316 Stainless Steel	91 PVC	
FITTINGS	1 None, 1/4" NPT	3 Polyflo; (4) 1/4" tube	4 Swagelok; (4) 1/4" tube (compatible with copper or poly tubing)

NOTES: 3-tube cable (15 ft./4.5 m) included with shipment.

\* Flanges have a titanium diaphragm, silicone rubber diaphragm configuration available, consult factory.  
 4" flange has a 8 bolt circle. 2" and 3" flanges have a 4 bolt circle.  
 All flanges are 150 lb. ANSI.  
 Special 3" 304 Stainless Steel brewery flange is available, consult factory.

**EXAMPLE**

Series ..... 92 Series  
 Flange size ..... 2"  
 Flange material ..... 316 Stainless Steel  
 Fitting ..... Polyflo; (4) 1/4" tube

**92 2 - 71 3**

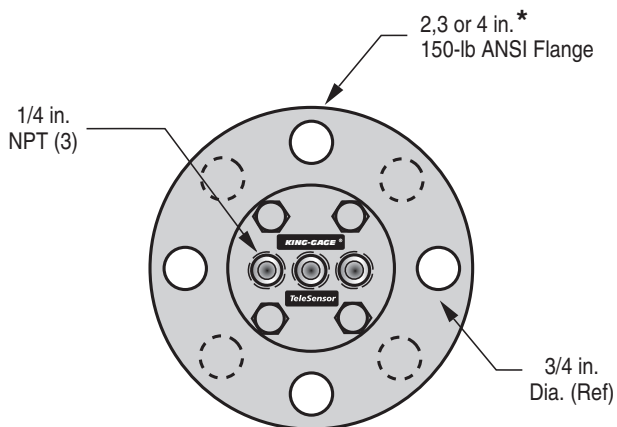

\* 4 in. Flange has 8 bolt circle, 2 and 3 in. Flange have 4 bolt circle.

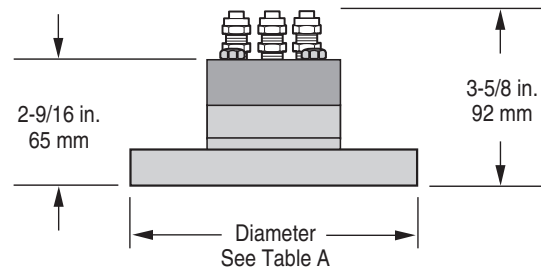

TeleSensor w/ Special 3-in. Brewery Flange (304 SS)

