

Installation and Operations Manual



v2 Model 5111-3x

Warranty - All KING-GAGE, A NOSHOK Company products are guaranteed to be free from defects in material and workmanship for one year from the date of purchase. Any product or part found to be defective under normal use within one year of purchase will be repaired or replaced at no charge if returned to the company in Berea, Ohio within a reasonable time of its discovery. No other warranties, whether expressed, implied or statutory, including the warranties of fitness for a particular purpose or merchantability, are given by this agreement. The exclusive remedy for nonconformity of these goods shall be repair and/or replacement of the nonconforming goods or parts.

Seller will not be liable for consequential damages resulting from breach of this agreement. The term "consequential damages" shall include but shall not be limited to damage to all machines, equipment and goods other than the goods sold hereby, interruption of production, loss of profits, delays of any kind, administrative expense and overhead.

Revisions:

- (A) December, 1993 – Original Release.
- (B) April, 1994 – Revised Indicator Scale text, added pages 12 & 13 and revised Signal Jumper drawing.
- (C) Added jumper wire note on page 10.
- (D) 734 Area code update/front cover pic

The information contained in this manual was accurate at the time of release. Specifications are subject to change without notice.

Contents

Specifications..... 3

Pneumatic Input (w/ Internal D/P Transmitter)..... 4

Indicator Scale 4

Pressure Connections..... 5

Power 5

Hand Pump Operation 6

User Details..... 6

Scale Installation/Removal 7

Troubleshooting..... 8

Revisions:

October 2010—Original v2 release

Model No. Designation

5111-30 LevelBAR HP, 0–5 psid
(application range 0–138 in. water/0–3.5 m water)

5111-31 LevelBAR HP, 0–10 psid
(application range 0–277 in. water/0–7.0 m water)

5111-32 LevelBAR HP, 0–15 psid
(application range 0–415 in. water/0–10.5 m water)

5111-33 LevelBAR HP, 0–30 psid
(application range 0–830 in. water/0–21.0 m water)

Specifications

Display Accuracy/Resolution
1%

Display Type
100-segment LED (light emitting diode)

Display Length
10" / 254 mm

Input Power
100–240 Vac, 50/60 Hz, source ground

Temperature Range (Environmental)
30° to 120°F (-1° to 49°C) operating range

Input Pressure Ranges
0–5, –10, –15, –30 psid fixed range transmitter element (accepts clean, dry air/gas pressure input). Maximum pressure rating is 300% FS. Minimum pressure range for proper operation is 50% of nominal. The lowest acceptable input pressure range is 0–2.5 psid using the 0–5 psid transducer element.

Transmitter Accuracy
0.5% FS

Physical Data
304 stainless steel housing and cover with polycarbonate display window. Intended to meet splash proof requirements (not suitable for heavy wash down) and use of waterproof conduit hubs or fittings may be required during installation.

IMPORTANT!
Not rated for explosion hazard designated areas.

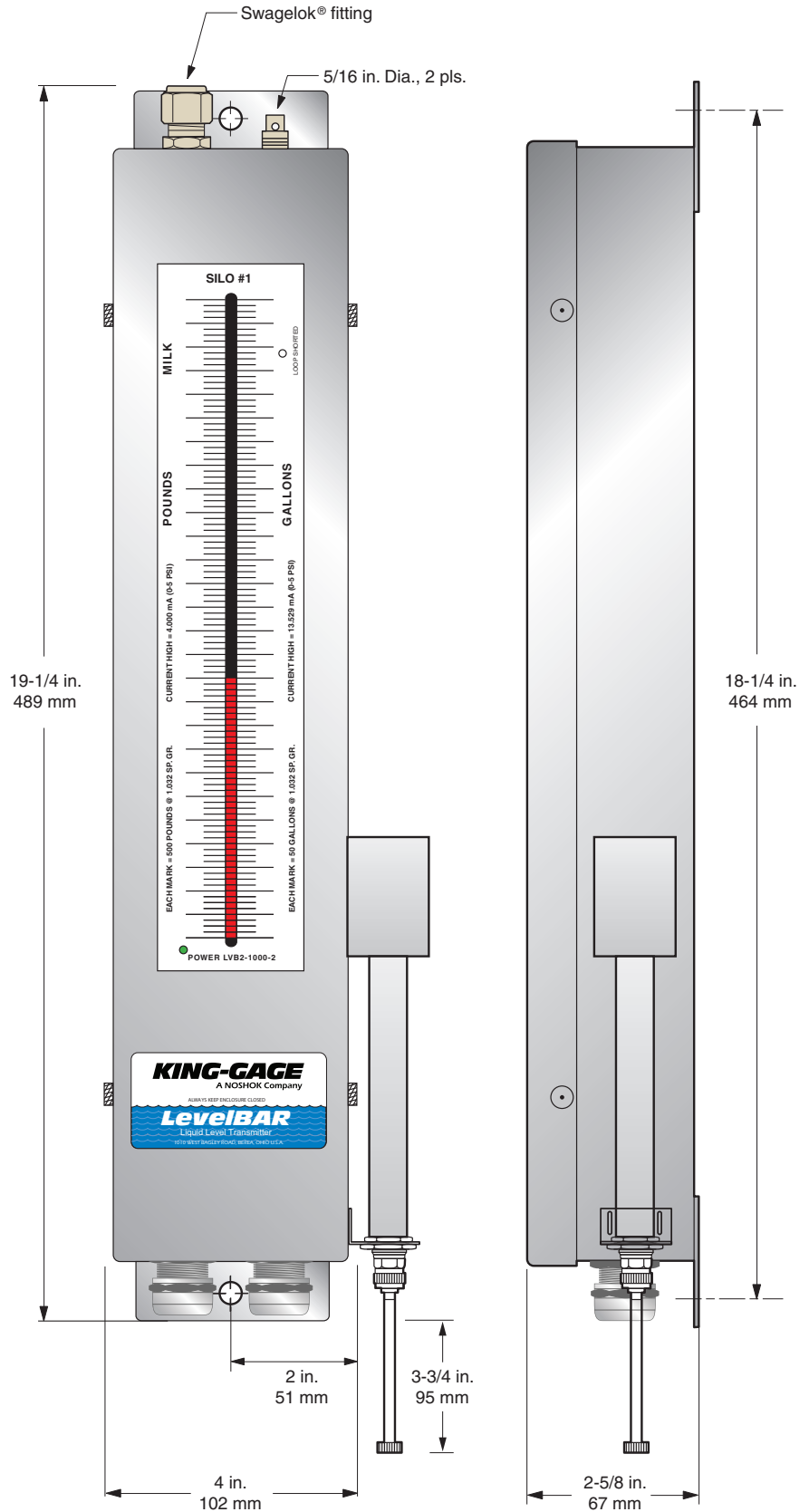

Pneumatic Input (w/ Internal D/P Transmitter)

The LevelBAR HP incorporates an internal fixed range electronic transmitter as part of the indicator package. This converts the pressure created by the hand pump to purge the downpipe of tank liquid into an electronic output to illuminate the LED display segments proportional to the depth. A scale ranging adjustment obtains full scale display where maximum pressure input is less than the transmitter upper pressure range.

Principle of Operation

When used with a downpipe (or bubbler tube), pressure is created by pumping the LevelBAR to displace the liquid from the downpipe. The amount of pressure created will be equal to the force created by the depth of liquid present in the tank also known as hydrostatic pressure. By measuring the pressure present within the downpipe, we are measuring the equivalent of the hydrostatic pressure. Knowing the specific gravity (density) of the liquid in the tank, it is possible to directly correlate the pressure to the physical depth measured up from the end of the downpipe.

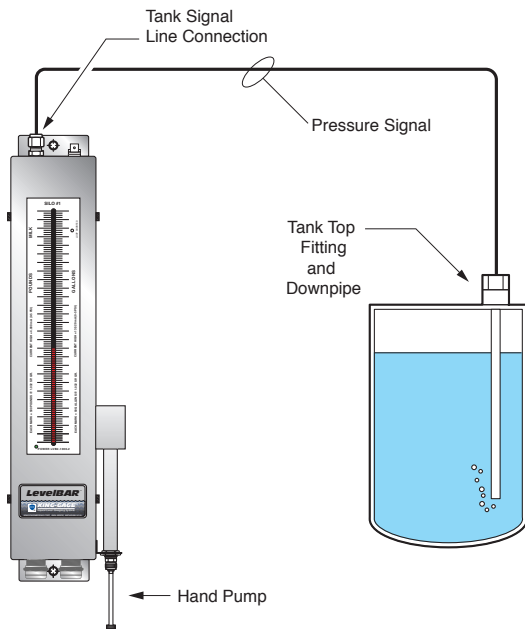

LevelBAR Hand Pump System

Indicator Scale

Scales are marked for readout in a specified unit of measurement such as weight (pounds, kilograms, tons) or volume (gallons, liters, barrels, etc.). Each scale is uniquely graduated based on pressure range, tank geometry and density (specific gravity) of the contents.

Tank Identification—The tank designation appears at the top of the scale.

Scale Serial Number—A unique LVB2-#### serial number appears at the lower left hand of each scale.

Scaling Adjustment Setting—Refer to “CURRENT HIGH =” notation on right hand edge of scale. This notes the scaling adjustment settings and pressure range of the transmitter.

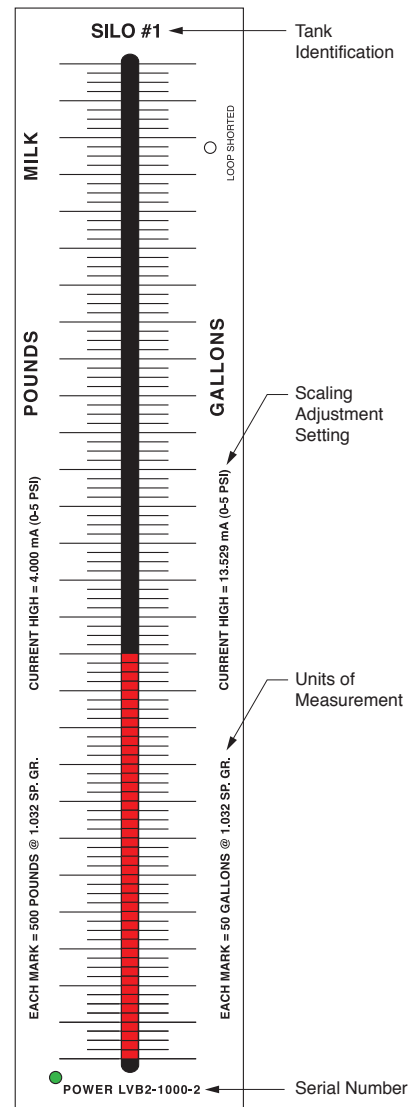

LevelBAR Scales are marked for the specific tank geometry. Liquid in the tank can be measured by volume or total weight.

Pressure Connections

The LevelBAR HP models include two (2) 1/8" NPT connection ports at the top of the enclosure. These are for **Signal** (high pressure) and **Equalizer** (low pressure) input. Since a majority of applications involve gage pressure relative to atmosphere, a vent plug is provided for the low pressure input.

Pneumatic (Pressure) Input Connections

- S** **Signal**—air purge and pressure line to downpipe. On a closed or non-vented tank gauging application (i.e., differential pressure measurement), this would correspond to the liquid depth pressure.
- E** **Equalizer**—In open or vented tanks, this connection is vented to atmosphere. (Steam and/or extremely wet situations may require routing vent line to a dry or protected location.) Otherwise, this connection is for low pressure input corresponding to void pressure above the liquid surface in a closed or non-vented tank.

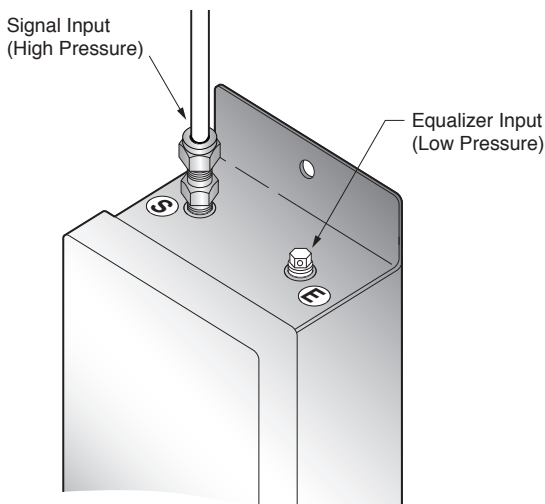
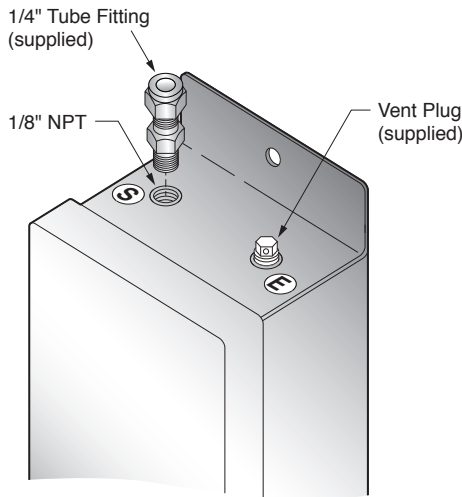

Power (100–240 Vac, 50/60 Hz)

Connect the LevelBAR indicator to a grounded 100–240 Vac, 50/60 Hz. power source. Source ground must be connected to terminal #2 (L1/GND/L2) as indicated. (Note that “hot” or “neutral” power conductors may be connected to either the L1 or L2 terminals.) Use only the supplied watertight cord grips or other watertight connectors (conduit) for the power cabling.

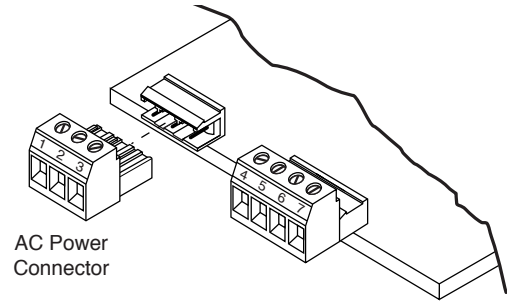

STATUS INDICATORS		7425-55
Green LED	Flashing, open current loop; Solid, normal (power)	
Red LED	On, loop short	

AC POWER			SIGNAL LOOP			
1	2	3	4	5	6	7
L2	GND	L1			Shield	
100–240 Vac 50/60 Hz					Signal + (Vdc)	
					Signal -	

Hand Pump Operation

The LevelBAR HP indicator uses the integral hand pump to pressurize the tubing line to the tank downpipe. When the pump is operated, a built-in air check valve opens to allow the compressed air to pass into the pressure line. The indicator LED column will stop rising when enough air is placed in the pressure line to clear the downpipe (bubble tube); air pressure is equal to the hydrostatic (liquid depth) pressure and excess air simply bleeds out the bottom of the downpipe.

Operating Sequence:

1. Pump the handle repeatedly while observing the individual LED segments begin to light.
2. When LED column stops rising, discontinue pumping and immediately read the level on the indicator.

Operational Note: Indicator reading should only be made immediately after pumping the system until the LED column stops rising. (Reading will be only valid for a few minutes due to subsequent loss of air pressure downstream—such loss may be caused by small leaks in the tubing run to the downpipe.)

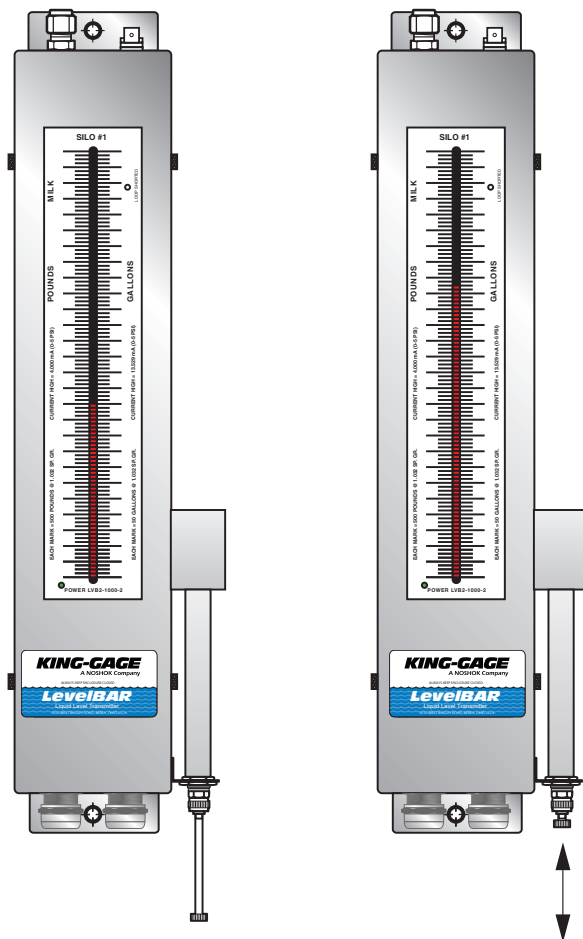

User Details

Bold indicates default settings

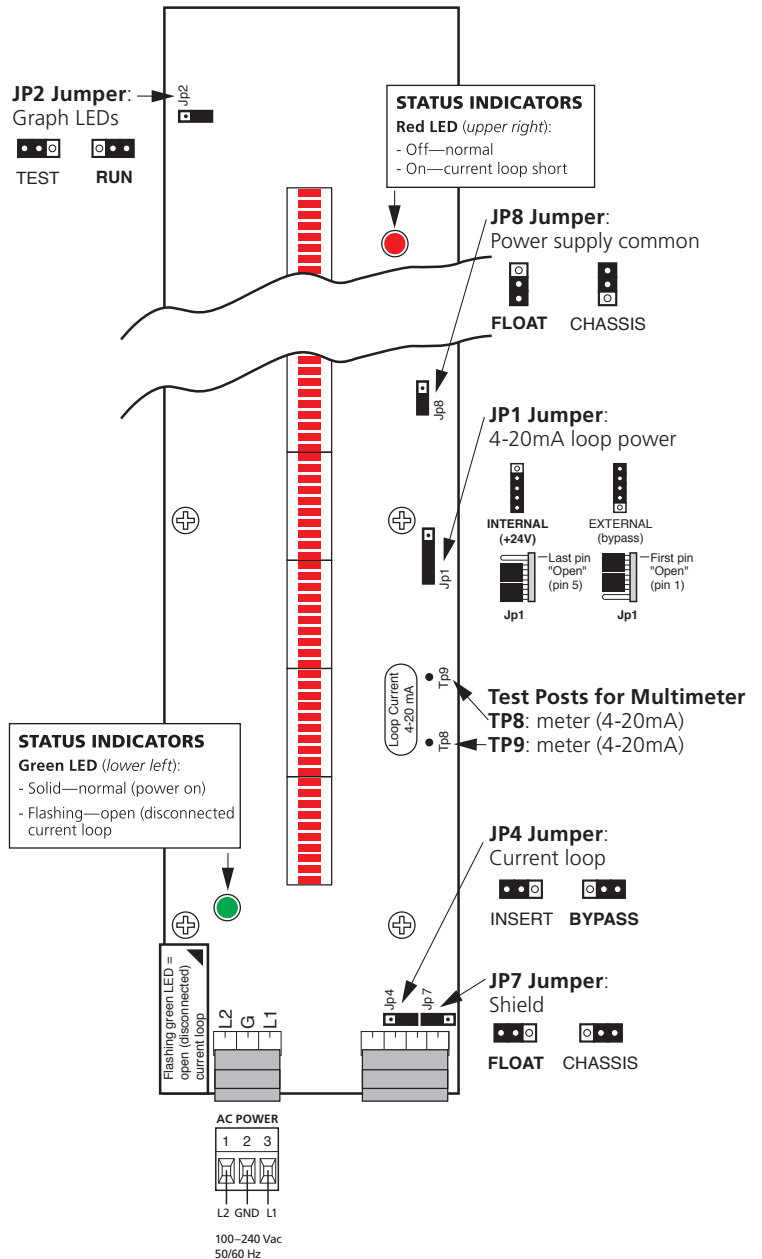

Status Indicators

The LevelBAR display incorporates two LED status indicators that are useful during installation and for troubleshooting operation. In the event of a short or fault in the internal circuit, a red LED will indicate “Loop Shorted” (refer to upper right hand corner of scale window).

Jumpers and Factory Default Settings

- JP1 Jumper: 4-20ma loop power—**internal** (default) / external
- JP2 Jumper: Graph LEDs—test / **run** (default)
- JP4 Jumper: Current loop—insert / **bypass** (default)
- JP7 Jumper: Shield—**float** (default) / chassis
- JP8 Jumper: Power supply common—**float** (default) / chassis
- R79: Graph span—99.5% default (of CURRENT HIGH)
- R88: Graph zero—0.5% default (of CURRENT LOW)
- TP8: meter – test point (4–20mA loop)
- TP9: meter + test point (4–20mA loop)

Scale Installation/Removal

The front cover must be removed to access the indicator scale. Refer to illustrations on page 7.

1. Remove four (4) thumbscrews on sides of housing to unfasten cover.
2. Scale Removal: From backside of cover, unthread the four (4) stand-offs to access scale.

3. Scale Installation: Once properly aligned, tighten stand-offs securely. The bottom mark on the scale should be aligned with the bottom edge of the first LED segment.

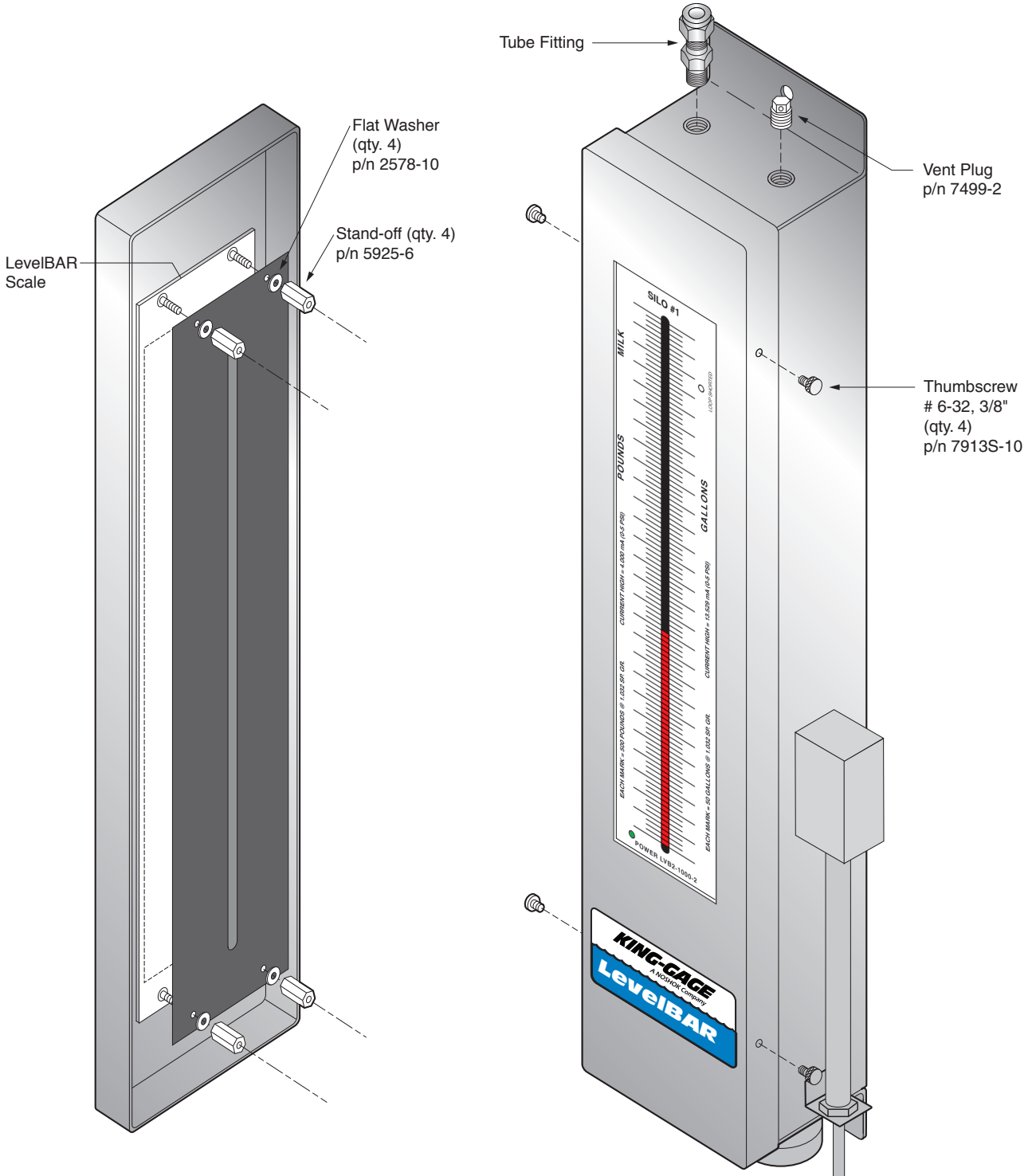

Troubleshooting the LevelBAR Indicator

1. No Display?

Try the following...

Check to see if Power indicator (green LED) is illuminated. If not, check AC power connection and power source.

If tank is empty (or there is no pressure in the down-pipe), the LED column will not be illuminated. Use the hand pump to generate pressure and see whether the LED column begins to light up.

Graph LEDs (Diagnostic Test Mode)

The LevelBAR LED column can be tested to ensure all individual segments are functional using the JP2 jumper at the upper left portion of the circuit board.

NOTE: For normal operation JP2 must be in the "run" position.

JP2 Test: causes all LED segments to light up (test only)

JP2 Run: normal display mode (LEDs light in response to signal input)

2. Display Reading Low?

Try the following...

Check for leaks in pressure tubing, tube fittings and/or internal transmitter pressure connections. Note that LevelBAR cannot display full scale if maximum pressure is less than 50% of the rated pressure range of the unit.

3. Display Reading High?

Try the following...

Pressure input to LevelBAR may be high due to restriction or blockage within downpipe in tank. If contents has a higher specific gravity than liquid for which scale was calibrated, display will not be accurate.