

A. Indicator Identification

The label on the front of the indicator case has an identification number that specifies the indicator model, case construction, range and type of indicating liquid used (Detail 1).

If scales have been factory installed, tank designation will appear on the scale to aid in proper location of indicator (Detail 2).

If 2 or more indicators are to be installed, be sure to identify the individual indicators, as outlined above. Determine the proper location for each indicator by referring to the tank designation printed on the scale (units with factory installed scales only).

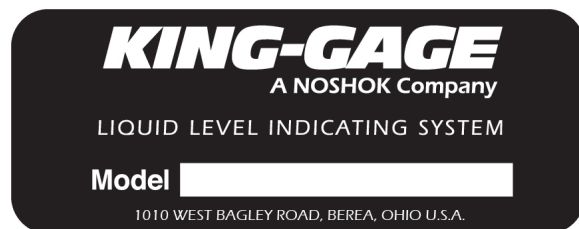

7750S - xx x-x

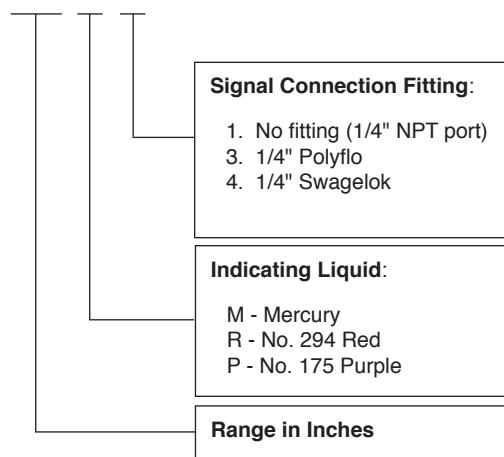

Detail 1 - Model Number Designation

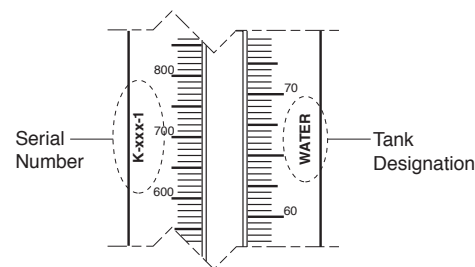

Detail 2 - Indicator Scale

B. Installation

CAUTION! Contains Liquid

This item contains a fluid fill as the indicating medium. **DO NOT REMOVE** seal plugs at the top of the case until the indicator has been mounted in a vertical position.



¡CUIDADO! Contiene Líquido

Note: The correct amount of indication liquid was placed in the indicator at fabrication. Trapped air may prevent liquid from showing in the glass tube until the sealing plugs have been removed.

- Mount the indicator rigidly in a vertical position. See Mounting Dimensions and refer to note D-1. KING-GAGE Indicators should be mounted so as to ensure visibility of display and accessibility for maintenance.
- Remove front cover and discard any packing material.
- Remove and *discard* hex head sealing plugs (Detail 3) from top of indicator case.
- Parts bag includes tube fitting, vent plug, and overflow check valve to complete the installation (Detail 4).

Overflow Check Valve

This check valve will prevent fluid fill from escaping if the indicator is overpressured.

- Thread the vent plug into the top of the check valve.
- Install this assembly into the front center connection (Detail 4).

Dimensions by Indicator Range:

Range	Dim. "A"	Dim. "B"
20.....	26-1/4.....	25-3/8
35.....	42-1/4.....	41-3/8
43.....	50-1/4.....	49-3/8
51.....	58-1/4.....	57-3/8
66.....	74-1/4.....	73-3/8
81.....	90-1/4.....	89-3/8

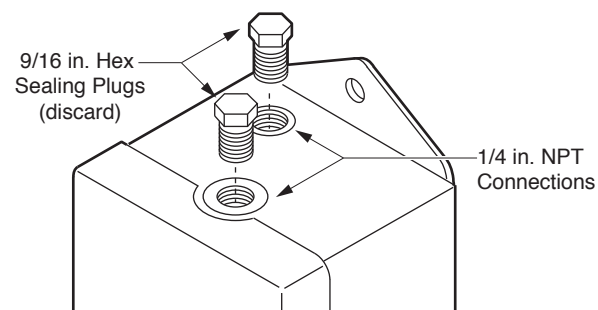

Detail 3 - Removing Sealing (Shipping) Plugs

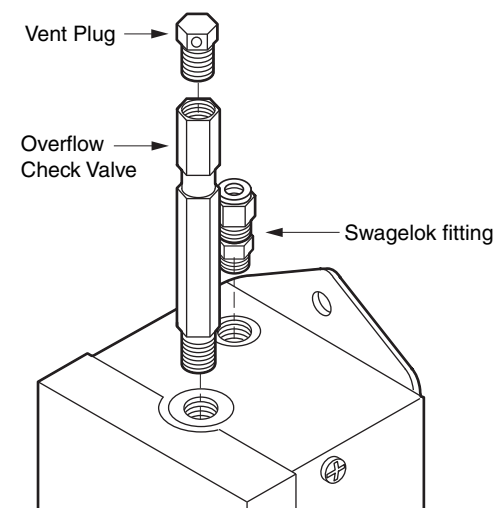

Detail 4 - Overflow Check Valve and Fitting Installation

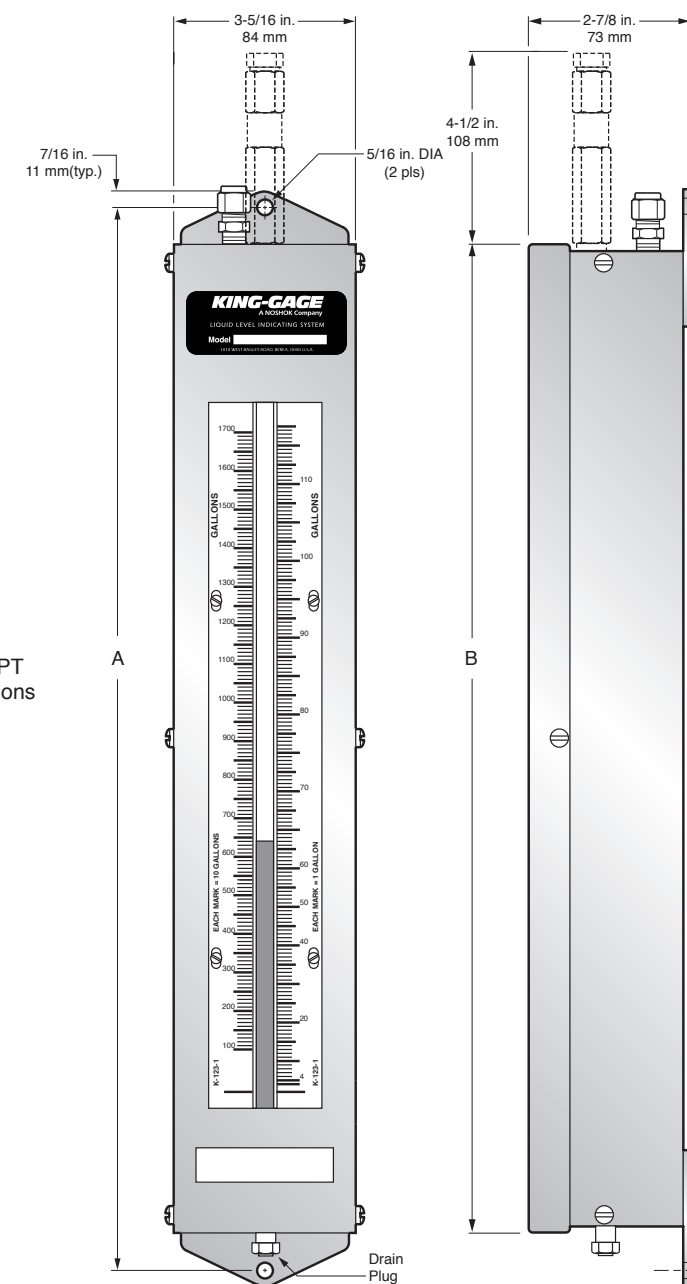

INSTALLATION INSTRUCTIONS

MODEL 7750 INDICATOR PNEUMATIC COLUMN DISPLAY

F	1/10	Caution! Contains Liquid	DATE	1/12/10
E	8/09	Revised details		
D	2/97	Redrawn per ECR 3318	DRAWN BY	D. Kennedy
C	6/91	Revised & Redrawn	APPROVED	

KING-GAGE
A NOSHOK Company

1010 West Bagley Rd., Berea, Ohio 44017
Ph 855.367.2494 www.king-gage.com

DWG. NO.

K-1000-4

SHEET **1** OF **2**

REV. **F**

C. Indicator Scales

Alignment Check: If scales (or calibration strip) have been factory-installed, refer to step 4 below. Check alignment only after indicator has been permanently installed. If scales have not been installed, proceed to Installation, below.

Caution: There must be no signal pressure to the indicator during either alignment or installation of scales.

Disconnect signal tubing at the indicator.

Installation: The scales are furnished in pairs, one for each side of the indicating tube. Serial numbers on scales should correspond to each other (Detail 2). Only after completing the installation of the indicator should the scales be installed.

C-1. Remove front cover.

C-2. Remove screws and washers from scale support brackets.

C-3. Place the scales on scale support brackets. Replace washers and screws, aligning appropriate holes. Do not tighten.

C-4. Align the lowest mark on the scale to coincide with level of liquid in glass tube. This is very important! Any variation will result in false readings (Detail 5).

C-5. Tighten scale support screws and replace front cover.

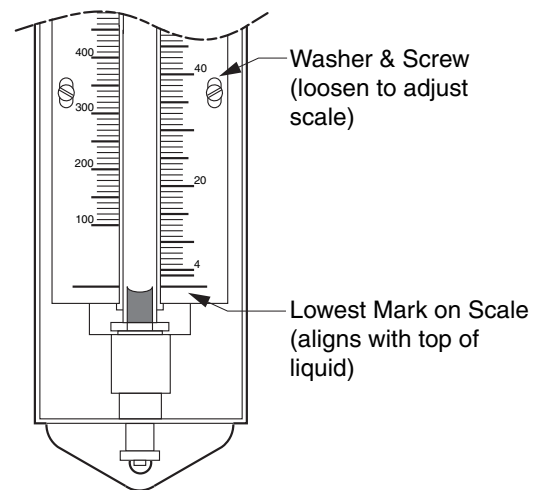

Detail 5 - Indicator Scale and Adjustment

D. Signal Tube Installation

The signal pressure tube connects the tank sensor control "G" port to the top of the indicator and conveys the tank signal pressure to the indicator. The tubing may be 1/4 in. O.D. or smaller (either copper, polyflo or nylon). Tank signal connection fitting is supplied (see Details 6 & 7).

D-1. Consideration should be given when running tubing so it is free and clear from excessively sharp bends for its entire length. Care should be taken to protect the tubing from possible abuse or damage.

Note: Tubing run to indicator must be a direct line! Do not "tee" into the system for any equipment which consumes air, or is not bubble tight. This will cause indicator to read incorrectly.

D-2. Install tube fitting into tank signal connection.

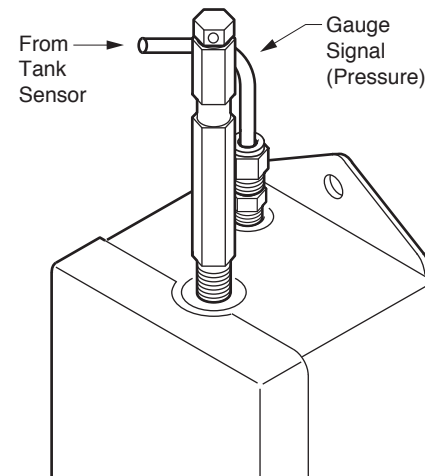

Detail 6 - Typical Tank Signal Connection

Differential Pressure Applications

(applies to non-vented systems, or systems with ambient equalization option)

Non-Vented Systems - The equalizer tubing is connected at the top of the indicator tube and at one of the following locations: either the "E" port of a Safeguard™ Tank Sensor Control or the "G" port of a purged equalizer control or directly from a tank equalizer fitting. Whichever is applicable to a specific system.

Equalizer Connection - The equalizer tubing conveys an equalizing signal to the indicator. The tubing may be 1/4 in. O.D. or smaller, either copper, poly-flo or nylon.

1. Equalizer tubing should be free and clear of any excessive sharp bends. Refer to note D-1.

2. Install equalizer fitting into center connection on top plate of indicator. If overflow check valve is used, equalizer fitting is threaded into top of overflow check valve.

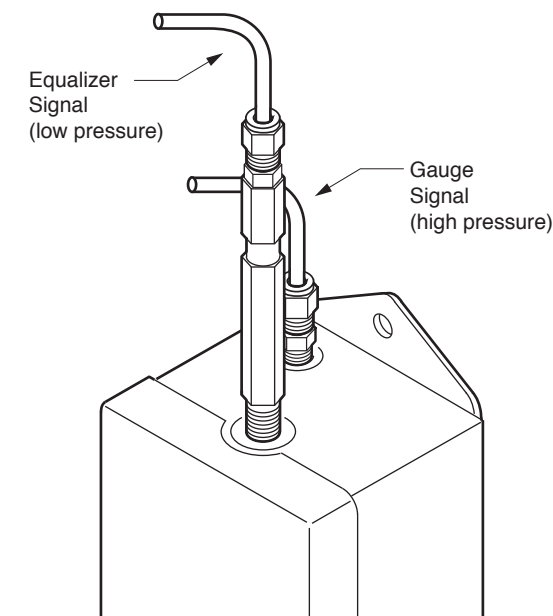

Detail 7 - Ambient Equalization Signal Connections

INSTALLATION INSTRUCTIONS

MODEL 7750 INDICATOR PNEUMATIC COLUMN DISPLAY

F	1/10	Caution! Contains Liquid	DATE	1/12/10
E	8/09	Revised details		
D	2/97	Redrawn per ECR 3318	DRAWN BY	D. Kennedy
C	6/91	Revised & Redrawn	APPROVED	

KING-GAGE
A NOSHOK Company

1010 West Bagley Rd., Berea, Ohio 44017
Ph 855.367.2494 www.king-gage.com

DWG. NO.

K-1000-4

REV.

SHEET **2** OF **2**

F