

Indicator Identification (Model & Serial No.)

The label on the front of the cover has the model number which specifies case material, range and type of indicating liquid (fluid fill) used. See Detail 1.

If scales have been installed, tank designation appears on top or side of scale. This should correspond to the applicable tank installation. See Detail 2.

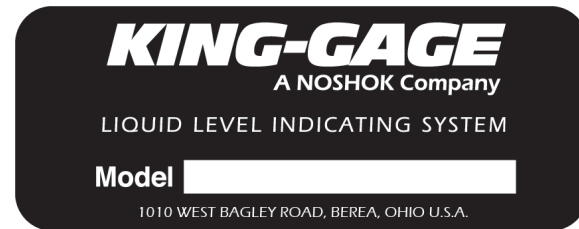

5992S - xx x

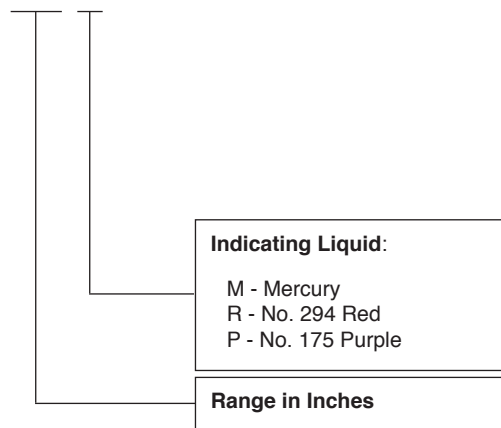

Detail 1 - Model Number Designation

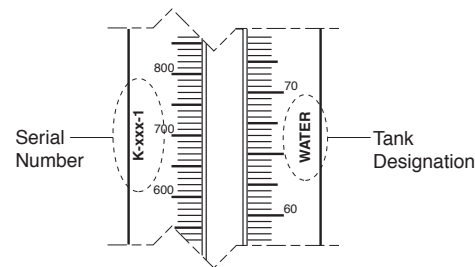

Detail 2 - Indicator Scale

Installation

CAUTION! Contains Liquid

This item contains a fluid fill as the indicating medium. **DO NOT REMOVE** seal plugs at the top of the case until the indicator has been mounted in a vertical position.



¡CUIDADO! Contiene Líquido

This KING-GAGE column indicator has a fluid fill which is sealed during shipment and installation. Do not remove seal plugs until the indicator has been physically mounted as outlined below.

Note: Trapped air may prevent fluid fill from showing in the glass tube until seal plugs have been removed.

- A-1. Mount indicator in a vertical position to a wall or other rigid structural member. Indicator should be located to ensure visibility of the display with adequate overall clearance for connections at the top and bottom of the housing. Refer to mounting dimensions shown.
- A-2. Remove front cover and discard any packing material.
- A-3. Remove and discard metal seal plug from center connection. Remove white vent plug from left hand connection and save for final installation. Remove and discard well tube plug (Detail 3).
- A-4. Parts bag includes tube fitting and overflow check valve to complete the installation (Detail 4).

Overflow Check Valve

This check valve will prevent fluid fill from escaping if the indicator is overpressured.

- B-1. Thread the vent plug into the top of the check valve
- B-2. Install this assembly into the front center connection (Detail 4).

Dimensions by Indicator Range:

| Range | Dim. "A" | Dim. "B" |
|-------|----------|----------|
| 20 | 26-1/4 | 25-3/8 |
| 35 | 42-1/4 | 41-3/8 |
| 43 | 50-1/4 | 49-3/8 |
| 51 | 58-1/4 | 57-3/8 |
| 66 | 74-1/4 | 73-3/8 |
| 81 | 90-1/4 | 89-3/8 |

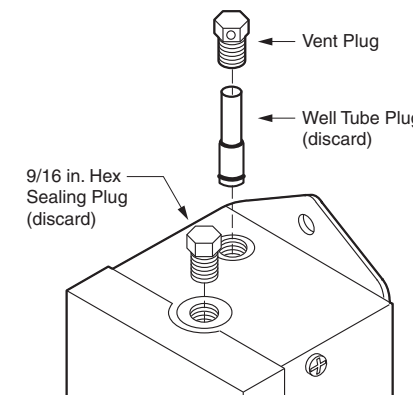

Detail 3 - Removing Sealing (Shipping) Plugs

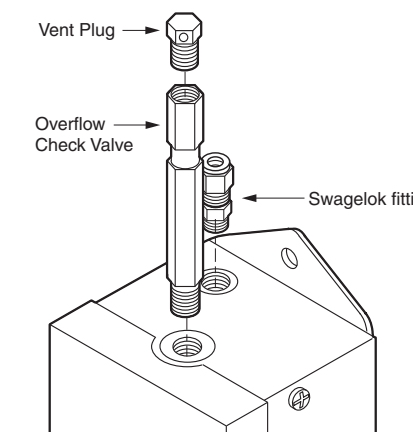

Detail 4 - Overflow Check Valve and Fitting Installation

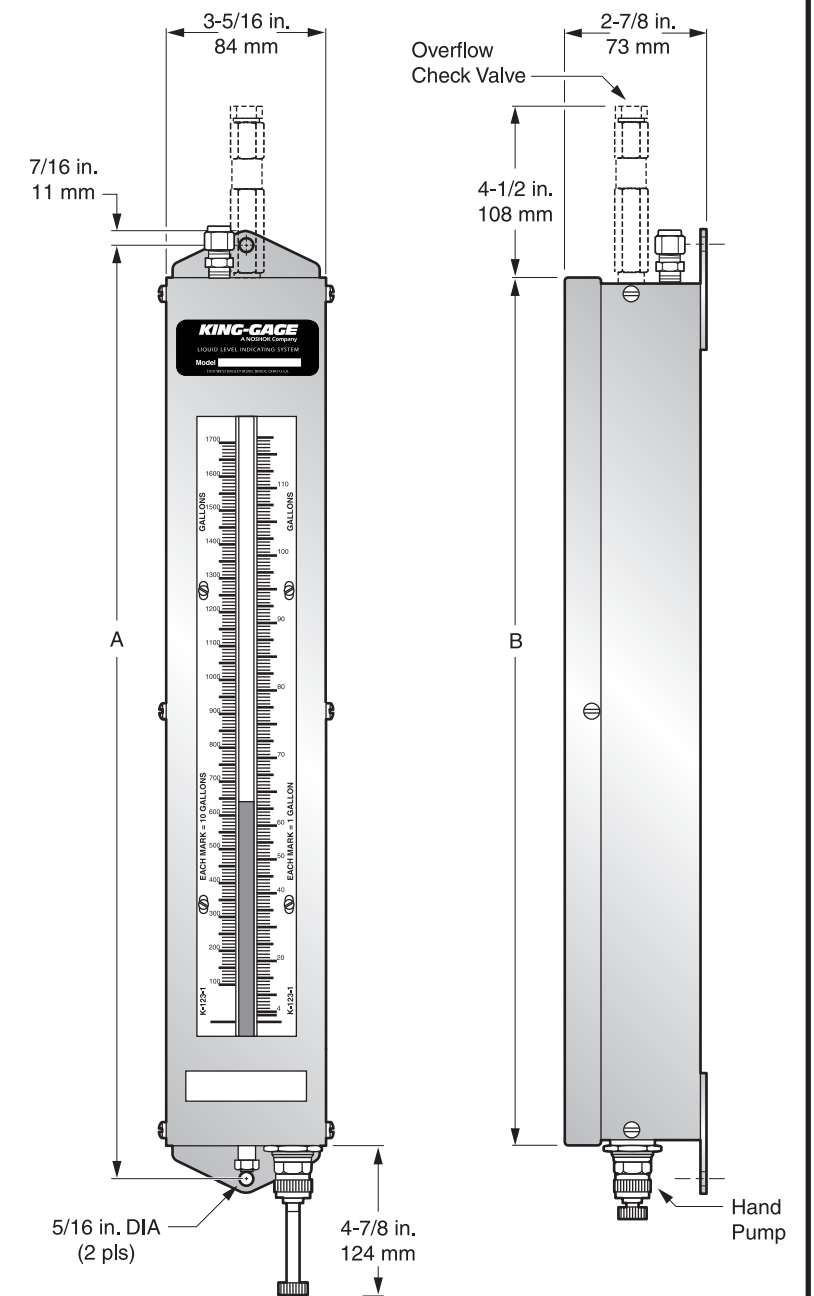

INSTALLATION INSTRUCTIONS

MODEL 5992 INDICATOR PNEUMATIC COLUMN DISPLAY

| | | DATE | 1/22/10 |
|---|------|------------------------------|---------------------|
| C | 1/10 | Caution! Contains Liquid | |
| B | 3/09 | revised top connection block | DRAWN BY D. Kennedy |
| A | 4/97 | released | APPROVED |

KING-GAGE
A NOSHOK Company

1010 West Bagley Rd., Berea, Ohio 44017
Ph 855.367.2494 www.king-gage.com

DWG. NO.
K-1000-50

SHEET **1** OF **2** **C**

Indicator Scales

Installation: Scales are furnished in pairs, one for each side of the indicating tube, with matching serial numbers (Detail 2). Install or align scales only after the indicator has been physically mounted.

Alignment Check: If scales have been factory installed, refer to step C-3 below to check alignment. Disconnect signal tubing or air supply line before making any adjustment to scale alignment.

- C-1. Remove front cover and remove any packing material (felt blocks, etc.)
- C-2. Scales are fastened to the support brackets using small screws and washers supplied. See Detail 5.
- C-3. Align the lowest mark on the scale to coincide with level of liquid in the glass indicating tube. Tighten screws to secure scales once properly aligned. Any misalignment will cause reading errors.
- C-4. Replace front cover and connect signal tubing and/or air supply line.

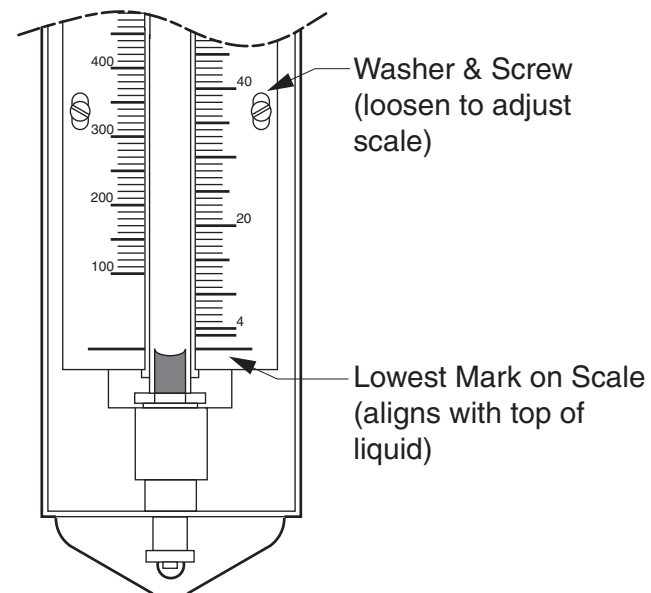

Detail 5 - Indicator Scale and Adjustment

Signal Tube Installation

The tubing between the tank downpipe and indicator. Tubing may be copper, nylon or polyflo of the appropriate diameter as recommended to convey the air flow to the downpipe and resulting pressure back to the indicator. Tank signal connection fitting is supplied (Detail 4).

- D-1. Route tubing to avoid sharp bends and minimize exposure to damage or high traffic areas. Recommended minimum tubing diameters –
 - 1/4" O.D. for distances up to 125 feet/38 m
 - 3/8" O.D. for distances up to 550 feet/170 m
 - 7/16" O.D. for distances greater than above
- D-2. Install tube fitting and connect signal tubing at indicator. Tubing must be leak-tight for its entire run. Do not tee into the signal tube for any equipment that consumes air.

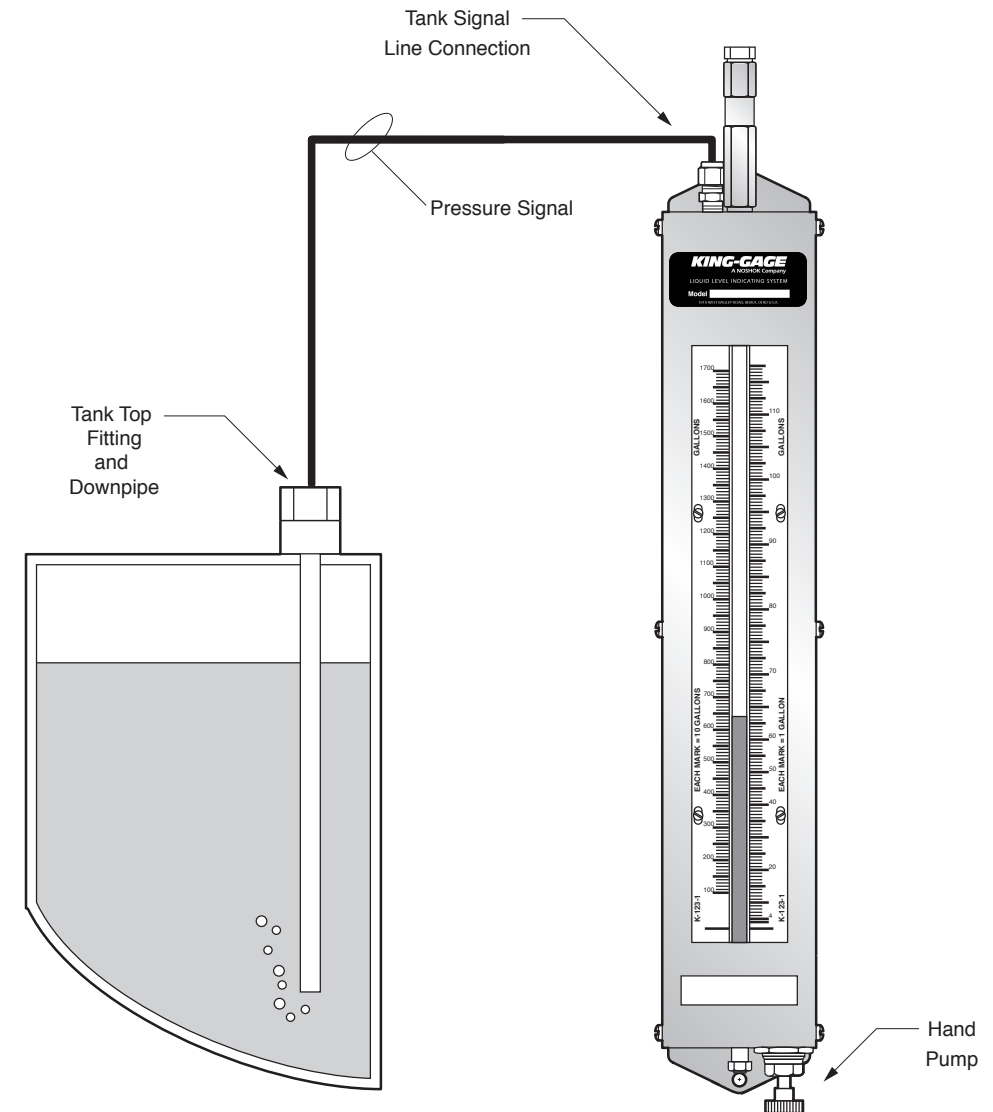

INSTALLATION INSTRUCTIONS

MODEL 5992 INDICATOR PNEUMATIC COLUMN DISPLAY

| | | DATE | 1/22/10 | DWG. NO. | K-1000-50 | |
|---|------|------------------------------|----------|--|-----------|--------|
| C | 1/10 | Caution! Contains Liquid | | KING-GAGE A NOSHOK Company 1010 West Bagley Rd., Berea, Ohio 44017 Ph 855.367.2494 www.king-gage.com | SHEET | 2 OF 2 |
| B | 3/09 | revised top connection block | DRAWN BY | | | |
| A | 4/97 | released | APPROVED | | | REV. |